



LG

Life's Good

ENGLISH

OWNER'S MANUAL REFRIGERATOR FREEZER

Please read this guide thoroughly before operating and keep it handy for reference at all times.



1800-180-9999 MTNL/BSNL (Toll Free)

39-01-0909 Prefix STD Code

LG Customer Information Center

Table of Contents

Introduction	Registration	4
	Important Safety Instruction	4
	Identification of Parts	16
Installation	Installation	17
	Starting	17
Operation	Temperature Control	18
	• Refrigerator	18
	• Freezer	18
	Function	20
	• Super Freezer	20
	• Vacation	20
	• Lock	21
	• Memory Feature	21
	• Door Alarm	21
	• Self Test	21
	Ice Making	21
	Defrosting	21
	Water Dispenser	22
Suggestion On Food storage	Storing Food	24
Care and Maintenance	General Information	25
	Lamp Replacement	25
	Cleaning	26
Trouble Shooting	Trouble Shooting	28
To Reverse the Doors	Precaution	30
	How to Reverse the Door	30

Introduction**Registration**

The model and serial number are found on the rear of this unit. This number is unique to this unit and not available to others. You should record requested information here and retain this guide as a permanent record of your purchase. Staple your receipt here.

Date of Purchase : _____

Dealer Purchased From : _____

Dealer Address : _____

Dealer Phone No. : _____

Model No. : _____

Serial No. : _____

Important Safety Instruction**BASIC SAFETY PRECAUTIONS**

This guide contains many important safety messages. Always read and obey all safety messages.

 This is the safety alert symbol. It alerts you to safety messages that inform you of hazards that can kill or hurt you or others or cause damage to the product. All safety messages will be preceded by the safety alert symbol and the hazard signal word DANGER, WARNING, or CAUTION. These words mean:

 **DANGER** You will be killed or seriously injured if you don't follow instructions.

 **WARNING** You can be killed or seriously injured if you don't follow instructions.

 **CAUTION** Indicates an imminently hazardous situation which, if not avoided, may result in minor or moderate injury, or product damage only.

All safety messages will identify the hazard, tell you how to reduce the chance of injury, and tell you what can happen if the instructions are not followed.

Important Safety Instruction

⚠ WARNING

To reduce the risk of fire, electric shock, or injury to persons when using your product, basic safety precautions should be followed, including the following. Read all instructions before using this appliance.

1. When connecting the power

The dedicated outlet should be used.

- Using several devices at one outlet may cause fire.
- The electric leakage breaker may damage food and the dispenser may be leaked.



Do not allow the power plug to face upward or to be squeezed at the back of the fridge-freezer.

Water may be flown into or the plug may be damaged, which causes fire or electric shock.

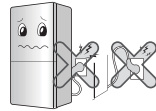

Do not allow the power cord bent or pressed by the heavy object to be damaged.

It may damage the power cord to cause fire or electric shock.



Do not extend or modify the length of the power plug.

It causes electric shock or fire by the electric damage of the power cord or others.



Unplug the power plug when cleaning, handling or replacing the interior lamp of the fridge-freezer.

- It may cause electric shock or injury.
- When replacing the interior lamp of the fridge-freezer, make sure that the rubber ring for preventing the electric spark within the socket is not taken off.



Important Safety Instruction

Do not pull out the cord or touch the power plug with wet hands.

- It may cause electric shock or injury.

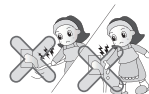

Remove water or dust from the power plug and insert it with the ends of the pins securely connected.

Dust, water or unstable connection may fire or electric shock.



Make sure of grounding.

Consult a qualified electrician or service person if the grounding instructions are not completely understood, or if you have doubts on whether the appliance is properly grounded or not.

The incorrect grounding may cause breakdown and electric shock.

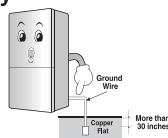

Be sure to use grounded exclusive proper voltage consent for the power plug.

It becomes the cause of fire.

When the power cord or the power plug is damaged or the holes of the outlet are loosed, do not use them.

It may cause electric shock or short circuit to make fire.



2. When using the fridge-freezer

Do not place the heavy object or the dangerous object (container with liquid) on the fridge-freezer.

It may be dropped to cause injury, fire or electric shock when opening or closing the door.



Do not cling to the door or the shelves of the door or the home bar of the freezer or the cool chamber.

It may make the fridge-freezer fallen down or damage the hands. Especially, do not allow the children to do the above.



Important Safety Instruction

Water tank can fill with potable water only.



Do not install the fridge-freezer in the wet place or the place which water or rain splashes.

Deterioration of insulation of electric parts may cause electric leakage.



Do not use or store inflammable materials ether, benzene, alcohol, medicine, LP gas, spray or cosmetics near or in the fridge-freezer.

It may cause explosion or fire.



Do not place the lit candle within the fridge-freezer to deodorize. Do not use drier to dry the inside, nor light a candle to remove odor.

It may cause explosion or fire.



Do not store the medicine or the academic materials at the fridge-freezer.

When the material with the strict temperature control is stored, it may be deteriorated or it may make an unexpected reaction to cause any risk.



Do not use the combustible spray near the fridge-freezer.

It may cause fire.



Important Safety Instruction

Avoid the heating devices. Install in places away from the fire such as the place where flammable gas is leaked.

It may cause fire.

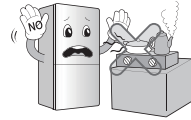

Do not place flower vase, cup, cosmetics, medicine or any container with water on the fridge-freezer.

It may cause fire, electric shock or injury by dropping down.



Use the submerged fridge-freezer after checking it.

It may cause electric shock or fire.



Do not spray water at the outside or the inside of the fridge-freezer or do not clean it with benzene or thinner.

Deterioration of insulation of electric parts may cause electric shock or fire.



Important Safety Instruction

When any strange smell or smoke is detected from the fridge-freezer, disconnect the power plug immediately and contact to the service center.

It may cause fire.



Do not allow any person except the qualified engineer to disassemble, repair or alter the fridge-freezer.

It may cause injury, electric shock or fire.

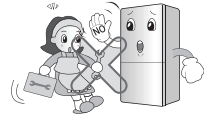

Do not use the fridge-freezer for non-domestic purpose (storing medicine or testing material, using at the ship, etc.).

It may cause an unexpected risk such as fire, electric shock, deterioration of stored material or chemical reaction.



When disposing the fridge-freezer, remove the packing materials from the door.

It may cause to lock out the child.



Install the fridge-freezer on the solid and level floor.

Installing it on the unstable place may cause death by falling down the fridge-freezer when opening or closing the door.



Important Safety Instruction

Do not insert the hands or the metal stick into the exit of cool air, the cover, the bottom of the fridge-freezer, the heatproof grill (exhaust hole) at the backside.

It may cause electric shock or injury.



When you want to dispose the fridge-freezer, contact to the down-block office.

When you want to dispose the large living waste such as electric home appliance and furniture, you'd better contact the local down-block office.



⚠ CAUTION

Violating this direction may cause injury or damage house or furniture. Always be careful, please.

Do not touch food or containers at the freezer with wet hands.

It may cause frostbite.



Wait for 5 minutes or longer when reconnecting the plug.

It may cause the operation of the freezer to fail.



Do not put bottle in the freezer.

It may freeze the contents to break the bottle to cause injury.



Pull out the power plug not by grasping the cord but the plug of its end.

It may cause electric shock or short circuit to fire.



Important Safety Instruction

Do not install the fridge-freezer in the wet place or the place which water or rain splashes.

Deterioration of insulation of electric parts may cause electric leakage.



Do not insert the hands into the bottom of the fridge-freezer.

The iron plate of the bottom may cause injury.



Carry the fridge-freezer with the handle bar at the bottom of the front and the top of the rear.

Otherwise, your hands may be slipped to cause injury.

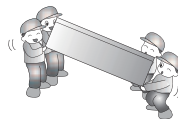

Because opening or closing the door of the fridge-freezer may cause injury to the person around it, be careful, please.

Opening or closing the door may cause feet or hands to be caught in the chink in door or the child to be get hurt by the corner.

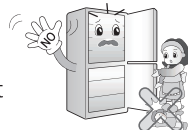

Do not put any living animal in the fridge-freezer.

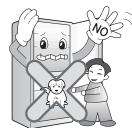

▲ CAUTION

This appliance is not intended for use by persons (including children) with reduced physical, sensory or mental capabilities, or lack of experience and knowledge, unless they have been given supervision or instruction concerning use of the appliance by a person responsible for their safety.

Children should be supervised to ensure that they do not play with the appliance.

Important Safety Instruction

⚠ WARNING

Precaution

- This fridge-freezer must be properly installed and located in accordance with the Installation Instruction before it is used.
- Never unplug your fridge-freezer by pulling on the power cord. Always grip plug firmly and pull straight out from the outlet.
- When moving your appliance away from the wall, be careful not to roll over or damage the power cord.
- After your fridge-freezer is in operation, do not touch the cold surfaces in the freezer compartment, particularly when hands are damp or wet. Skin may adhere to these extremely cold surfaces.
- Pull out the power plug prior to cleaning the fridge-freezer.
Never damage, severely bend, pull out, or twist the power cord because power cord damage may cause a fire or electronic shock.
Never place glass products in the freezer because they may be broken when their inner contents are frozen.
- Do not directly spray water inside or outside the fridge/freezer.
There is a risk of explosion or fire.
- Do not insert the power plug with wet hands.
You may receive an electric shock.
- Do not put a container filled with water on top of the appliance.
If the water spills on to any electrical parts, it may lead to fire or electric shock.
- Do not install the fridge/freezer in a damp place, where it could be splashed with water.
Incorrect insulation of the electrical parts may cause an electric shock or fire.

Important Safety Instruction

- **Do not disassemble, repair or alter the appliance.**
It may cause fire or abnormal operations, which may lead to injury.
- **Pull the power plug out of the socket before replacing the interior light in the refrigerator.**
Otherwise, there is a risk of electric shock.
- **If possible, connect the fridge-freezer to its own individual electrical outlet to prevent it and other appliances or household lights from causing an overload.**

It will cause electric shock or fire.



Do not modify or extend the Power Cord length

Don't Use on Extension Cord

Accessibility of Supply Plug

Supply Cord Replacement

⚠ DANGER

Don't store

Grounding (Earthing)

If possible, connect the fridge-freezer to its own individual electrical outlet to prevent it and other appliances or household lights from causing an overload.

The supply plug of the refrigerator-freezer should be placed in easy accessible position for quick disconnection in emergency.

If the supply cord is damaged, it must be replaced by the manufacturer or its service agent or a similarly qualified person in order to avoid a hazard.

Risk of child entrapment.

Before you throw away your old refrigerator or freezer:
Take off the doors.

Leave the shelves in place so that children may not easily climb inside.

Don't store or use gasoline or other flammable vapors and liquids in the vicinity of this or any other appliance. In the event of an electric short circuit, grounding (earthing) reduces the risk of electric shock by providing an escape wire for the electric current. In order to prevent possible electric shock, this appliance must be grounded. Improper use of the grounding plug can result in an electric shock. Consult a qualified electrician or service person if the grounding instructions are not completely understood, or if you have doubts on whether the appliance is properly grounded.

Important Safety Instruction

⚠ CAUTION

- If the wall socket is loose, do not insert the power plug.
It may cause electric shock or fire.
- Never unplug your refrigerator by pulling on the power cord. Always grip plug firmly and pull it straight out from the outlet.
You may disconnect a wire and cause a short circuit.
- Do not use a wet or damp cloth when cleaning the plug. Remove any foreign matter from the power plug pins.
Otherwise, there is a risk of fire.
- Do not put your hands into the bottom area of the appliance.
Any Sharp edges may cause personal injury..
- After unplugging the appliance, wait for at least five minutes before plugging it again to the wall socket.
Abnormal operation of the freezer may cause material damage.
- If the appliance is not to be used for a long time, pull out the power plug.
Any deterioration in the insulation may cause fire.
- Do not let children touch or play with the control panel on the front of the appliance.
- The refrigerant used in fridge/freezer and the gases in the insulation material require special disposal procedures. Ensure that none of the pipes on the back of the appliances are damaged prior to disposal.

Important Safety Instruction

⚠ WARNING

Prevent the power cord from being squeezed or imprinted if the refrigerator is pushed in after the power plug is extracted during the installation.

It becomes the cause of fire or electric shock. When moving your appliance away from the wall, be careful not to roll over or damage the power cord.

Prevent children from entering the product.

It may endanger the life of a child if the child enters the refrigerator.



Opening and closing the door of the refrigerator vigorously may cause the stored food in the refrigerator basket to fall by shock and hurt the foot, so take precautions.

In case of thunder and lightning, or not in use for a long period of time, detach the power plug.

There is a danger of electric shock or fire.

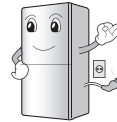

Please do not use a dishwasher to clean the lower drawers; the high temperature may cause damage to the baskets which make them unusable.

⚠ CAUTION

Do not place the food in disorder inside the refrigerator.

The food may fall during opening and closing the door of the refrigerator and hurt people.

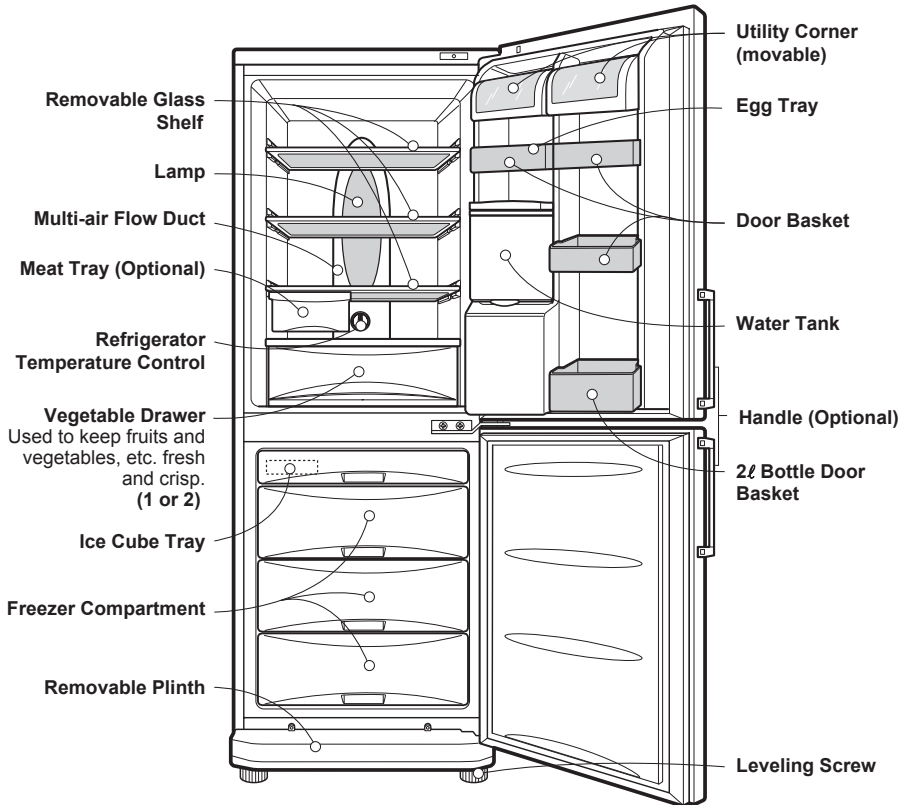

Identification of Parts



Note

If you find some parts missing from your unit, they may be parts only used in other models.

Installation

1. Select a good location.
Place your fridge-freezer where it is easy to use.
2. Avoid placing the unit near heat sources, direct sunlight or moisture.
3. There must be proper air circulation around your fridge-freezer to keep it operating efficiently.
4. To avoid vibration, the unit must be leveled.
If required, adjust the leveling screws to compensate for the uneven floor.
The front should be slightly higher than the rear to aid in door closing.
Leveling screws can be turned easily by tipping the cabinet slightly.
Turn the leveling screws counterclockwise() to raise the unit, clockwise() to lower it.
5. Clean your fridge-freezer thoroughly and wipe off all dust accumulated during shipping.
6. Install accessories such as ice cube box, etc., in their proper places.They are packed together to prevent possible damage during shipment.
7. Connect the power supply cord (or plug) to the outlet.
Don't double up with other appliances on the same outlet.
8. To ensure proper air circulation around the fridge - freezer, please maintain sufficient space on both the sides as well as top and maintain at least 2 inches (5 cm) from the rear wall.

Starting

When your fridge-freezer is installed, allow it 2-3 hours to stabilize at normal operating temperature prior to filling it with fresh or frozen foods.

If power plug is disconnected, allow 5 minutes delay before restarting.

Your fridge-freezer is now ready for use.

Temperature Control

Your fridge-freezer has two controls that let you regulate the temperature in the fridge and freezer compartments.

Refrigerator

- Initially set the TEMP. CONTROL at "4". Then adjust the compartment temperature according to your desire.

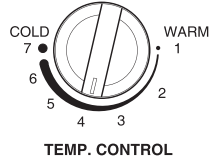

- If you want an inside temperature slightly less cold or colder, turn the knob towards WARM or COLD, respectively. When the surrounding temperature is low, adjust the TEMP. CONTROL 'WARM'.

Freezer

Display Panel For Temperature Control

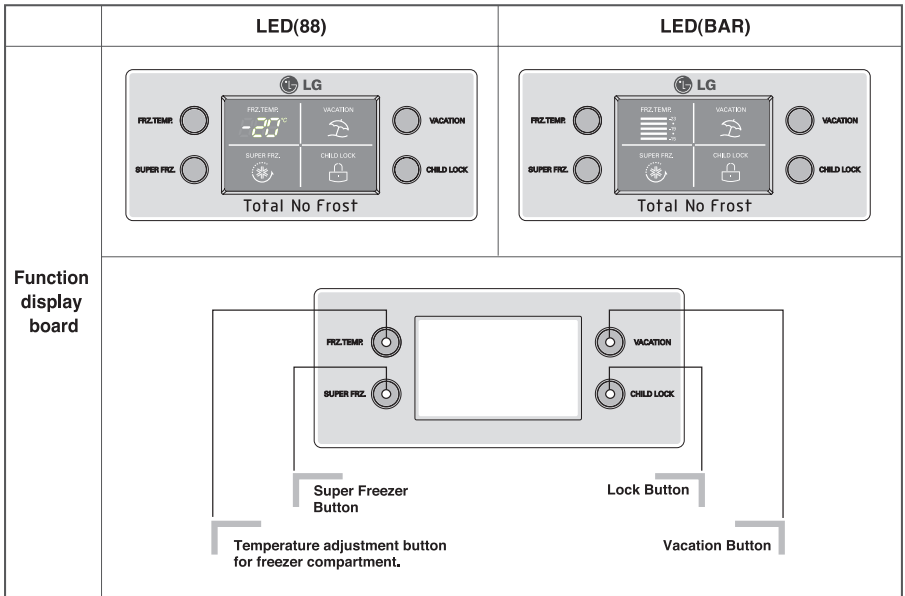

- You can now adjust the temperature of the compartment as you want.

< LED 88 Type >



< LED BAR Type >



- When you press the temperature control buttons, the temperature of Freezer compartment is repeated in the following order.

LED 88 Type Freezer Compartment :

-19°C → -20°C → -21°C → -22°C → -23°C → -15°C
→ -16°C → -17°C → -18°C

LED BAR Type Freezer Compartment :

-19°C → -21°C → -23°C → -15°C → -17°C

Note

The actual inner temperature varies depending on the food status, as the indicated setting temperature is a target temperature, not actual temperature within refrigerator.

Refrigeration function is weak in the initial time. Please adjust temperature as above after using refrigerator for minimum 2~3 days.

Super Freezer

Function

- Please select this function for prompt freezer.
- This function is used when you want to freeze the foods quickly. Press the 'SUPER FRZ.' (Super Freezer) button once, and then the quick freeze operation starts with the lamp on.
- The Super Freeze operation takes about 3 hours. When its operation ends, it automatically returns to the previous temperature setting. If you want to stop the quick freeze operation, press the 'SUPER FRZ.' button once more, the lamp goes out, and the Super Freeze operation stops and the refrigerator returns to the previous temperature setting.



Vacation

- This function makes the fridge-freezer work in a power saving mode which is useful for when you are away on holiday, by reducing energy consumption as much as possible. Pressing 'VACATION' starts operation with lamp on and pressing it again stops the operation.



Lock

- Pressing this button stops operation of other buttons.
- "Locking" or "Un-Locking" is repeated whenever pressing the 'CHILD LOCK' button. (For "Locking" or "Un-Locking" press the 'CHILD LOCK' button for 2 secs.)
- When 'CHILD LOCK' is activated, pressing the other buttons would not work.



Memory feature

Function to save the set temperature and vacation status . When the power is turned on after the power failure, it will be restored with the set temperature and vacation status.

Door Alarm

- 3 times of warning of 30 seconds if a minute passes with the door of refrigerator opened or not completely closed.
- Please contact with the local service center if warning continue to sound even after closing the door.

Self Test

- This function automatically detects failure when failure is found in product during the use of refrigerator.
- If the failure occurs at product and it does not operate by pressing any button and normal indication is not done, do not turn the power off and immediately contact with the local service center.
- A lot of time is needed for service engineer to detect the failed part by turning it off.

Ice Making

- To make ice cubes, fill the ice tray to the water level and place it in the freezer.
- If ice cubes are required fast, press the 'SUPER FRZ.' button.
- To remove ice cubes, hold the tray at its ends and twist gently.



Tip

To remove ice cubes easily, run water on the tray before twisting.

Defrosting

Defrosting takes place automatically.

The defrosting water flows down to the evaporating tray and is evaporated automatically.

Water Dispenser

Features

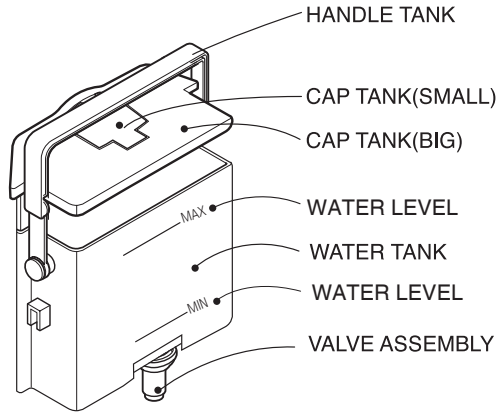
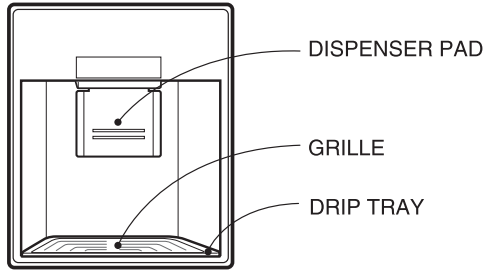

Install

- Please assemble the VALVE ASSEMBLY after correctly adjusting it with a DOOR HOLE.

**Filling of
WATER TANK**

1. After turning the HANDLE Tank backward with the WATER TANK installed at the DOOR, Open the CAP TANK (SMALL) and then fill water using a kettle etc.
* Fill water while watching a sight glass on the front of the WATER TANK.
* Water up to 4.5 ℓ can be filled.
2. Press and fix the CAP TANK(SMALL).
3. After filling spring water, fix the HANDLE TANK at a proper position.

Drinking

1. Press the Dispenser Pad with a cup.
2. If pressing the Pad, water inside of the Dispenser is supplied.
3. If slowly removing a cup from the Pad, water will not fall down.

Water level

- MAX: Leakage may happen if the water lever is higher than the lever MAX. The water lever should be kept under the MAX.
- MIN: There is less pouring water if the water lever is lower than the lever MIN. The water amount should be added before using.

▲ CAUTION

Do not use other beverage (milk, juice, carbonated beverage etc) than spring water. Especially beverage including grain must not be used (may result in failure).

Storing Food

Storing Food

- Do not store food which goes bad easily at low temperature, such as banana, and melon.
- Allow hot food to cool prior to storing. Placing hot food in the fridge-freezer could spoil other food, and lead to higher electric bills.
- When storing the food, use a container with a lid. This prevents moisture from evaporating, and helps food to keep its taste and nutrients.
- Do not block air vents with food. Smooth circulation of cold air keeps fridge-freezer temperature even.
- Do not open the door frequently. Opening the door lets warm air enter the fridge-freezer, and cause temperature to rise.
- To adjust the temperature control easily, do not store food near the temperature control dial.
- Never keep too many foods in door rack, as this may stop the door from fully closing.
- Do not store bottles in the freezer compartment - they may break when frozen.
- Do not refreeze food that has been thawed. This causes loss of taste and nutrition.
- Do not store pharmaceutical products, scientific materials or other temperature sensitive products in the refrigerator.
Products that require strict temperature controls must not be stored in the refrigerator.

Note

If you keep the fridge-freezer in a hot, and humid place, frequently open its door or put a lot of vegetables in it, dew may form in it, which has no effect on its performance.

Remove the dew with dust cloth free from care.

General Information

Power Failure

- 1~2 hour power failure does no harm to the foods stores. Try to avoid opening and closing the door too frequently.

If You Move

- Take out foods from the fridge-freezer and firmly fix the loose items with tape.
- Turn the leveling screws until they stop before moving the fridge-freezer. Otherwise the screw may scratch the floor or the fridge-freezer cannot move.

Anti Condensation Pipe

- The Anti-Condensation pipe is installed around the front side of fridge-freezer as well as on the partition between fridge compartment and freezer compartment to prevent dewing.
- Especially after installation or when ambient temperature is high, the fridge-freezer may feel hot, which is quite normal.

Anti-Condensation Pipe

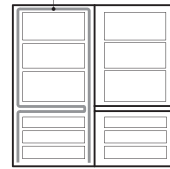

Lamp Replacement

Use a DC12V 0.75W LED lamp broad.

If LED lamp is damaged, it should be replaced by the service center in stead of on your own.

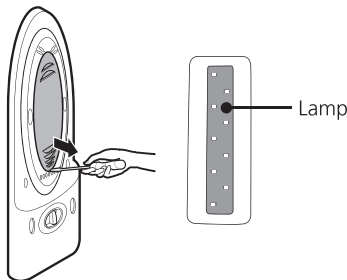

Cleaning

Before Cleaning

Be sure to unplug the power.

Exterior

Clean the outside of the fridge-freezer with a soft cloth soaked with hot water or liquid detergent. If you use a detergent, be sure to wipe it with a clean wet cloth.

Interior

As above.

After Cleaning

Check that the power cord is not damaged, power plug has not overheated, and that the power plug is tightly inserted into the outlet.

WARNING

Be sure to dry the appliance with a cloth after washing it with water.

Do not use abrasive, petroleum, benzene, thinner, hydrochloride acid, boiling water, rough brush, etc, as they may damage parts of the fridge-freezer.

Disposal of the old appliance

This appliance contains fluid (refrigerant, lubricant) and is made of parts and materials which are reusable and/or recyclable. All the important materials should be sent to the collection center of waste material and can be reused after rework (recycling). For take back, please contact with the local agency.

GRILLE and DRIP TRAY

Remove the GRILLE , wipe moisture out around the DOOR part and the DRIP TRAY using a clean cloth.

Exterior Dispenser

Wipe moisture etc out outside of Dispenser and on the DISPENSER PAD using a cloth.

WATER TANK

1. Lift the WATER TANK up by pressing the fixing LEVER on the bottom of WATER TANK and then remove it.
2. After removing the CAP TANK (BIG), clean and fully rinse the inside/outside part of the WATER TANK by using neutral cleansing agent.

CAP TANK (Big & Small)

Clean and fully rinse the CAP TANK (Big & Small) by using neutral cleansing agent.

Especially for the groove part of the CAP TANK, it is convenient to cleanse it by using a small brush.

VALVE ASSEMBLY

Clean and fully rinse the VALVE ASSEMBLY by using a small brush. Rinse it while operating the bottom part of the valve assembly. Always fix the Sealing Rubber separated for cleansing at the existing position (may result in water leakage).

Trouble Shooting

Before calling for service, check this list.

It may save you both time and expense.

This list includes common occurrences that are not the result of defective workmanship or materials in this appliance.

Problem	Possible Causes
Fridge-Freezer does not operate	<ul style="list-style-type: none"> • Power plug may be unplugged from the electric outlet. Plug it in securely. • House fuse has blown or circuit breaker has tripped. Check and/or replace fuse and reset circuit breaker. • Power cut. Check house lights.
Fridge or Freezer Compartment Temperature too warm	<ul style="list-style-type: none"> • Temperature control not set on proper position. Refer to Temperature Control section. • Appliance is placed close to heat source. • Warm weather-frequent door openings. • Door left open for a long time. • Package holding door open or blocking air duct in freezer compartment.
Vibration or Rattling or Abnormal Noise	<ul style="list-style-type: none"> • The floor on which the fridge-freezer is installed may be uneven or the fridge-freezer may be unstable. Make it even by rotating the leveling screw. • Unnecessary objects placed in the back side of the fridge-freezer.
Frost or Ice Crystals on frozen Food	<ul style="list-style-type: none"> • Door may have been left ajar or package holding door open. • Too frequent or too long door openings. • Frost within package is normal.
Moisture forms on Cabinet Surface	<ul style="list-style-type: none"> • This phenomenon is likely to occur in a wet space. Wipe it with a dry towel.

Problem	Possible Causes
Moisture collects inside	<ul style="list-style-type: none"> • Too frequent or too long door openings. • In humid weather, air carries moisture into fridge when doors are opened.
Fridge has odor	<ul style="list-style-type: none"> • Foods with strong odors should be tightly covered or wrapped. • Check for spoiled food. • Interior needs cleaning. Refer to CLEANING section
Door not closing properly	<ul style="list-style-type: none"> • Food package is keeping door open. Move packages that keep door from closing. • Fridge-freezer is not level. Adjust the leveling screws. • The floor on which the fridge-freezer is installed may be uneven or the fridge-freezer may be unstable. Slightly raise the front side with the leveling screw.
Interior light does not work	<ul style="list-style-type: none"> • No power at outlet. • Light lamp needs replacing. Refer to the Lamp Replacement section

To Reverse the Doors

Your fridge-freezer is designed with reversible doors, so that they may open from either the left or right hand side to suit your kitchen design.

Precaution

1. Before reversing the door, first of all, you should take out food and accessories like shelves or trays which are not fixed in the fridge-freezer.
2. Use Torque Wrench or Spanner to fix or remove the bolt.
3. Do not lay the fridge-freezer down. This will cause problems.
4. Be careful not to drop the doors in disassembling or assembling.

How to Reverse the Door

1. To separate the door handle ① of the left side, separate the door cap ② and unscrew the screw ③ in counterclockwise direction. Separate the door handle ④ of the freezer in the same order. (You do not need to follow the above procedure for the hidden handle.)
2. After unscrewing the screw ⑥ of the right hinge cover ⑤ on the top, separate the right hinge cover ⑤ to separate the connecting cable ⑨. Separate the bolt ⑦ fixing the upper right hinge ⑧, and carefully separate the refrigerator door ⑩. Remove the left cover ⑪.
3. After separating the upper left cap ⑫ of the separated refrigerator door ⑩, carefully take off the top cap ⑫ and pull the hole on the left side. Set the separated top cap ⑫ at the regular position and set the cap ⑪ on the cable hole on the right side. Loosen the screw ⑬ ⑭ under the cold room door ⑩, move it to the left of the stopper ⑰ ⑱, and then connect it.
4. Use a sharp gimlet or knife to disconnect the cap ⑮ from the cover front ⑲, loosen the screw ⑲, and then move the cable ⑲ to the left to be mounted. Disconnect the cable ⑲ and the door switch ⑳ from the disconnected cover front ⑲, swap the position of the disconnected cable ⑲ and door switch ㉑ with the cap ㉒, mount them, fix them with the screw ⑲, and then install the cap ⑮.

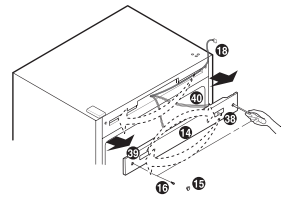
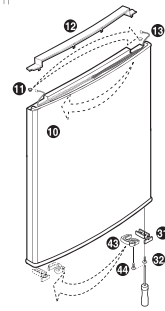
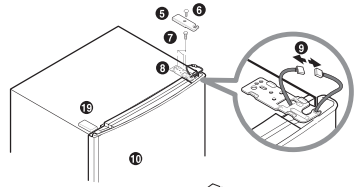
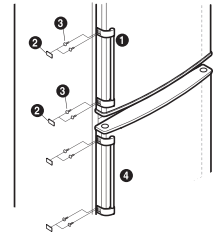

5. Loosen the bolt 20 of the Hinge Middle 21, remove the Hinge Middle 31, and lift up the freezer door 30 to separate it. (When separating the refrigerator door, separate the bush 35 together.) Separate the hinge cover 24 and set it on the separated part of middle hinge 21. After unscrewing the screw connected to the bottom cover 25 connect the cover cap 26 on the right side.

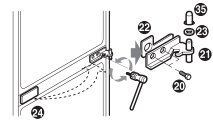

Loosen the bolt 27 connected to the lower hinge 28. Unscrew the screw 32 44 fixing the door stopper 31 43 at the bottom of the freezer door 30, and fixate it on the hole on the left side with the door stopper 31 43, and then, move the upper cap 33 to the right and cover it.

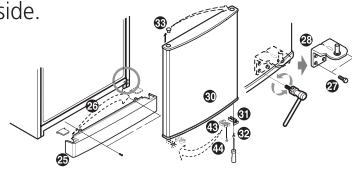

6. Set the separate lower hinge 28 and put it in the bag, take out the lower left hinge 45 of the bag and set the lower left hinge 45 on the bottom hole of the left side of the freezer then tighten the bolt 27. After fixing the bottom cover 25 at the regular position, align the freezer door 30 on the pin of lower hinge 45 to attach it properly. Turn over the separated middle hinge 21 and sheet hinge 22 to assemble them. And set the bush 35 and washer 23 together to tighten the bolt 20. (When tightening the bolt, be careful not to cause a scratch on the cap decor on top of the freezer door).

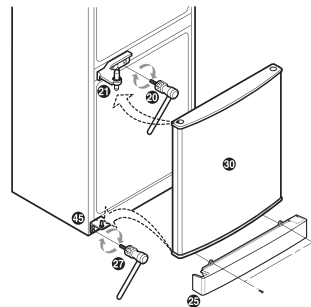

7. After assembling the door by aligning the hinge hole on the bottom of the refrigerator door 10 and the pin of the middle hinge 21, take out the upper left hinge cover 36 and the left hinge 37 of the bag. After connecting the cable 9, tighten the bolt 7 to screw the screws 6 to the left hinge cover 36. Take the right cap 42 out of the bag and clean up the wire, then install it on the right side of the refrigerator top.

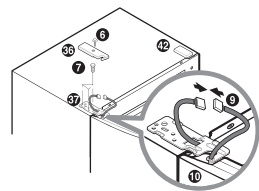

8. Move the separated door handle 1 to the right and fixate the screw 3 on the right position to attach the door cap 2. Move the door cap 41 on the right side to the left and attach it. Attach the freezer door handle 2 in the same method as the refrigerator door handle 1.

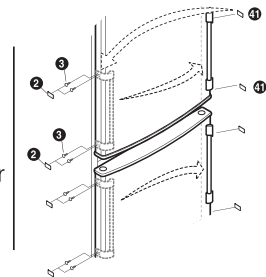

Note

Reversing the doors is not covered by the warranty.

For any further information, please contact LGEIL Branch & Remote Area Offices

Branch / RAO Addresses

Ahmedabad	101-102, Narayancomplex, Near Navrangpura Busstand, Navrangpura Ahmedabad - 380 009. Tel : 079-26562794, 26407633,34,35
Mehsana	GL-41, Apollo Enclave, Opp Jainderasar, Highway,Maisana,Gujrat, Tel : 9825600404
Agra	28 Gulmohar Vatika,Shilla Road,Khandan Crossing Agra, Tel : 0562-2530913,2530917
Jhansi	200/1,Behind National Bakery,Sipri Road,Civil Lines,Jhansi, Tel : 9839508012
Asansol	Block-E,Ist Floor,P C Chattarjee Market,Rambanhu Tala,GT Road (E) Asansol-713303, Tel : 0341-3096036, Mob : 3092009,3092010
Siliguri	3rd Mile,Sevoka Road,Siliguri-7134401, Tel : 9434006690
Midnapore	BE-27,Bidhannagar,Midnapore, Tel : 9830522899
Aurangabad	207-B, Tapadiya Super Market, Nirala Bazaar Road, Samartha Nagar, Aurangabad - 431005, Tel : 0240-2344705
Jalgaon	Nanded & Jalgaon Area office is on finalisation stage, Tel : 9823317119, 9823317113
Nasik	Flat No:6, Vijay Tower, Opposite Telephone Exchange, Canada Corner Saralpur Road,, Nasik-422105,, Tel : 9823317006
Amritsar	690,Batala Road,Amritsar,Punjab, Tel : 0183-5096753
Gurdaspur	SCO-19, Gurunanak Market, Opp. LIC Office, Shastri Nagar, Batala., Tel : 9855409012
Bhatinda	142, C/O Pipul Care Centre,Bibi Wala Road Bhatinda, Tel : 0164-2222448
Sangrur	C/o Sigma Enterprises, Gola Market, Sangroor
Ferozpur	C/o Saini industries, Bagdadi Road, Ferozpur, Tel : 9814435428
Bangalore	93,TKN Mansion, Ground Fir, KH Road, Bangalore- 560027, Tel : 080-51145145, Mob : 30910754,30910753
Mysore	No.763, 12th Main, Near Akshay Bandar, Kuvempunagar, Mysore - 570 023.
Bhopal	3 Malik Warehouse, J K Road ,Bhopal, Tel : 0755-5262847, 5262848,5260717, Mob : 3092938 , 3959804
Gwalior	C/o Electrocare, Anuj Sadan,Opp. Dainik Bhaskar Lane, Jayendra Ganj,Gwalior, Tel : 0751-3958510, Mob : 9826722553
Jabalpur	C/o K.M.Marketing Associates, 472, K.S House,Katangi Road, Karmeta,Jabalpur, Tel : 0761- 3097858, 5016847, Mob : 9826722552
Satna	C/o Satna Services, Gali No.1,Pushraj Colony, Satna(M.P), Tel : 07672-309705, Mob : 9826722554
Bhubaneshwar	Plot No.02,1st Flr.,Bapuji Nagar, Bhubaneshwar- 751009, Tel : 0674-2531430, 2534280, Mob : 3966525,3966526
Rourkela	Qtr. No: L-129, Phase - 1, Basanti Colony, Rourkela - 12.
Behrampur	Gandhi Nagar, Main Road, Opp: Indian Gas, BEHRAMPUR - 01, Tel : 9937099009
Calcutta	1, Ho-Chi-Min-Sarani, 6th Floor, Metro Towers, Calcutta-700071, Tel : 033-22883250/51, Mob : 30946125
Barackpore	195 Barasat Road, Near Panasia Nursing Home , 24 Paraganas (North), Kolkata - 700 122, Mob : 9830191903
Chandigarh	Plot No 177-G, Ind. Area, Phase-1, Chandigarh, Tel : 0172-5087389,90, Mob : 3959595,3959596
Dharamshala	301, Civil Lines, Dharamshala, Tel : 01892-229194, Mob : 9816050402
Chennai	AA11, 2nd Avenue, Fatima Tower, Anna Nagar West, Chennai-600040, Tel : 044-55510500-08, Mob : 30924478,30924479
Vellore	No. 3, Post office-3,Krishnanagar,Opp. Venus Theatre,Vellore-1, Mob : 9894721033
Cochin	40/1270, Vasudeva Buildings, T.D.Road, Ernakulam Cochin-682011, Tel : 0484-2368966, 2370744, Mob : 3946877,3946878
Kottayam	C/o Maria Electronics, Goodshed road, Ozhathgil Lane, Kottayam, 686001, Mob : 9895399809
Trivendrum	Hi-Tech Electronics,Hrishikesh,PC 25/2829, Mathrubhumi Road,Trivandrum -35, Mob : 9895399815
Coimbatore	250a, Sangnanur Main Road, Kannappa Nagar, Coimbatore-641027, Tel : 0422-2332506, 2331862, Mob : 3094613,3094573
Salem	F-13, Indira Gandhi Road, Fairlands, Salem-636016, Mob : 9843204202
Delhi (South)	221,Okhla Industrial Area, Phase-III, New Delhi, Tel : 011-26830953, 26837347, Mob : 30989283,30989365/66/67,30989278,30989358
Delhi (West)	13 Milestone, Rohtak Road, Opp Maharaja Agrsen Hospital,Punjabi Bagh,ew Delhi-110026, Tel : 011-9873002340/9873002339
Dehradun	M- 22, Mobbewala, Tata Commercial Compound, Dehradun Saharanpur Road, Dehradun, Tel : 0135-2644213,2644283
Haldwani	Church Compound, Behind PNB, Advocate Jasgish Kr. Bldg, Nanital Road, Haldwani, Mob : 9897173003
Goa	Plot No-D-3&D-4, Rego Baug, Alto Santacruz, Bambolim, Goa-403, Mob : 3094755,3094955,3094956
South Goa	D-3-4, Rego Bagh, Alto St.Cruz, Bambolim, GOA, Mob : 9850478909
Gurgaon	11 nd Fir, A Block, Centre Point Bldg, Sushant Lok , Gurgaon, Tel : 0124-5047461-62 - 63, Mob : 3950019,3099959
Hissar	SCF-2, Red square market, Near Bank of Baroda, Railway Road ,Hissar, Mob : 9811354295
Ghaziabad	J-10, RDC Rajnagar Ghaziabad, Tel : 0120-2722973, 2724686, 3943465, 3943467, Mob : 3943465,3943467
Bareilly	218, Chitrakot Building, Chander Gupt Hotel Lane, Bareilly, Tel : 955812422673/72, Mob : 9837066696
Meerut	A-8, Garh Road, Near Raja Rani Banquet Hall, Meerut, Tel : 95121-3099920/21, Mob : 9837778124
Guwahati	Shantineer Bhawan, C K Aggarwal Path, Chenikerthi, Guwahati-781003, Tel : 0361-2668984, 2662896, 2666395, 2666958, 2666958
Jorhat	K B Road, Near: L.I.C. Office, Jorhat, Tel: 0376-2301057, Mob : 9864028139
Silchar	N.N. Dutta Road, Near Jain Temple, Silchar District - Cachar, Assam, Mob : 9864029750
Hyderabad	K/1/1,IDA, Uppal, Hyderabad -500039, Tel : 040-27207504,05,06, Mob : 30921140
Warrangal	D. No-1-7-1788, Below Labour Office, BalaSamudram Main Road, Hanmakonda,Warangal, Mob : 9849989552
Hubli	603/1B, Ravi Nagar Road, Behind Renuka Petrol Pump, Gokul Road, Hubli-580030, Tel : 0836-2337251,52,53, Mob : 3090749,3090651
Mangalore	2/116, Aspinwall & Co Godown, Opp to Aspinwall & Co., Kulshekar - Maroli Road, Maroli, Mangalore - 575005, Mob : 9845941038
Gulbarga	No.-1-21/4,Mehta Compound, Court Road, Gulbarga, GULBURGA-585102, Mob : 9845941005
Shimoga	Opp. Sapthagiri Finance,Jail Circle, Kuvempu Road, SHIMOGA-577201, Mob : 9845941006
Belgaum	Jyoti Suraj Bldg, CCB-101,Maratha Colony, Off-congress road ,Tilakwadi, BELGAUM-590006, Mob : 9845941030
Indore	3rdflr.,304 Bansri Trade Centre,581/5 M. G.Road,Indore-452003, Tel : 0731-5065523-24, 2546985, 25065669, Mob : 3956060,3956065
Jaipur	B-71, Shankar Marg, Lal Kothi Scheme,Jaipur-302015, Tel : 0141-2741553, 2742639, Mob : 3951458,3951478
Alwar	Plot No. 234A, II/3, State Bank Colony, Police Line, Ajmer-305001, Mob : 9829213525



Branch / RAO Addresses

Jalandhar	Opp Jassi Market, Village Khajurla, Near TVS Godown Jalandhar -Phagwada, G T Road, Jalandhar, Tel : 01824-502,667,502,668,502,000
Hoshiarpur	C/o GIDDA Complex, Near Sale Tax Office, New Hari Nagar Railway Road, Hoshiarpur, Mob : 9814924553
Jammu	Plot No.-52, Transport Nagar, Narwal, Jammu, Tel : 0191-2477420, 2477419, 2474396, 2474384
Srinagar	1-A, Arabian Complex, RajBagh, Srinagar, Mob : 949135809
Jodhpur	22 (1-A), RIICO Heavy Industrial area, Jodhpur - 342003, Tel : 0291-2274203, 2742384, , Mob : 3093487(Accounts), 3093489
Bikaner	II B-9, Jai Narayan Vyas Colony, Shiv Bari Road, Opp Krishna Marriage Place, Bikaner-334003, Rajasthan, Tel : 0151-2230115
Sikar	Mob : 9829213531
Kundli	Sunshine Enterprises, Sunder Cold Storage, Gt Karnal Road, Kundli-Sonipat , Tel : 0130-2219201, 2219202, 2219203, 2219204
Ambala	Plot No. 4261-62, Punjabi Mohalla, Cross Road No. 2, Near Vijaya Bank, Ambala Cantt. 133001, Tel : 0171-2600355
Kozhikode	11 / 434, Erannikkal Bldgs, Cherooty Road, Kozhikode- 673001 Kerala, Tel : 0495-2366755, 2366756, 2366678
Lucknow	537, Hari Kunj, Keshav Nagar, Sitapur Road Lucknow, Tel : 0522-2757538, 39, 58, 59, Mob : 39515078/9
Kanpur	117/Q/70, 120 Ft. Road, Shardanagar, Kanpur, Mob : 9839014446
Sitapur	447 Aryanagar, Sitapur, Mob : 9839173524
Ludhiana	Village Jhande, Near Badowal Railway Station, Opp ferozpur Road Ludhiana, Tel : 0161-2804412 - 15, Mob : 3959985
Patiala	(Richie Electronics) LG Care Centre, Upper Mall, Opposite polo ground, Patiala, Mob : 9814649420
Ropar	(Anukar Utility Service) LG Care Centre, SCF - 56, Phase-II, Mohali, Mob : 9814088934
Madurai	7-1-54, Jothimal Godown, Madurai Dindigul Highroad, Paravai, Madurai-625402 Tamilnadu, Tel : 0452-2464016
Tirunelveli	No:71, Trivandrum High Road, Palayamkottai, Tirunelveli-627002, Mob : 9843204316
Mumbai(North)	Unit No.3, L Wing, 2nd Flr., Tax Center, Behind HDFC Bank, Off Saki Vihar Road, Chandiwali, Andheri(E), Mumbai-400072, Tel : 022-28472410-14
Mumbai(south)	108/109, Nav Neelam Bldg, Near Flora Restaurant, R G Thadani Marg, Worli, Mumbai- 4000018, Tel : 022-24971357, 26244427, 56244428, 29, 30, 31
Nagpur	5a, Road No.13, Behind Msrtc Workshop, Midc Hinga, Nagpur-440016, Tel : 07104-235120, 235122, Fax: 234401, Mob : 3092641, 3092642
Akola	C/o Anand Building, New Bhagat plot, Behind Indraprastha Road, Akola, Mob : 9822255336
Patna	B-8, Shakra Manzil, S K Puri, Patna, Tel : 0612-2211373, 2236580, Mob : 3098714
Bhagalpur	F/O, LIC Building-II(Old), R.B.S.S.S.Road, Bhikhanpur, Bhagalpur - 812 001, Mob : 9431022463
Gaya	Sumitra Sadan, Boring Road Crossing, Patna, Mob : 9431022465
Muzaffarpur	New Bela Ashram Road, Mithanpura Chowk, Muzaffarpur
Pune	105/106, Pride Silicon Plaza, Senapati Bapat Road, Pune-411016, Tel : 020-4030100, Mob : 30922960, 30967366, 30915833, 30967635
Solapur	940/2 "Garud Bungalow", North Sadar Bazar, Solapur- 413003, Tel : 0217-2317403, Mob : 9823317096
Kolhapur	517/10, Sawali Bungalow, Near Vikram high school, Shivaji park, Kolhapur 416 001
Pune Plant	Plot A-5 MIDC, Ranjan Gaon, Tahseel Shirur Distt.-Pune, Tel : 02138-232268/69/70
Raipur	Nathani Compound, Shyam Nagar, Katora Talab, Raipur(C.G), Tel : 0771-5037470, 5053171, Mob : 3959707, 3959708
Bilaspur	Hari Kishan Colony, Near PGBT College, High Court Road, Bilaspur - 495 001, Chattisgarh, Tel : 07752 - 515164, Mob : 9826139333
Ranchi	402, Commerce Tower, Opp. Gel Church Complex, Main Road, Ranchi, Tel : 0651-2331519, 2331815, Mob : 3090426
Dhanbad	Mouja-Dhansar, Moja No. 52, Khata No. 30, Plot no. 101,102,103, Opp: Dhansar Thana, Dhansar, Dhanbad , Jharkhand, Tel : 0326-2306884
Jamshedpur	4, 5 Ravindra Nagar, New Kasidih ,Road No -1, Sakchi, Jamshedpur, Cell : 9431104061, 9431104052
Rajkot	301, 302 Dhanrajni, Dr. Yagnik Road, Rajkot - 360001, Tel : 0281-2481499, 2467692, Mob : 3094093, 3094096
Jamnagar	102, Cozy Hill, Bedi Bandar Road, Pt. Nehru Marg, Jamnagar - 362 005, Tel : 0268-2753916, Mob : 9825612179
Bhavnagar	UL-40, Pattani Plaza, Nr. Nilam Bag Circle, Dairy Road, Bhavnagar - 364 002, Tel : 0276-2524685
Bhuj	12, Second floor, Shree Swaminarayan Vanijya Sankul Building, Main Hospital road, Bhuj - 370001, Mob : 9825610041
Surat	1001-1004, Ascon Plaza, IInd Flr, Anand Mahal Road, Behind Bhulka Bhavan School, Adajan, Surat-395009, Tel : 0261-2730982 - 85, Mob : 3954419
Baroda	204, Silver Line Complex, Opp. BBC Tower, Sayajigunj, Baroda - 390 005, Tel : 0265 - 222 59 70/71, Mob : 9879106703
Thane	Ad-1-13, Rajlaxmi Commercial Complex, Opp. Durgesh Park, Village-Kalher, Thane- Bhiwandi Highway Dist.-Thane-421302, Tel : 02522-277497/27755
Vashi	Mangalmurti Chamber, HB Builder Shop No.-4, Plot No-17, Sector No.-30 Opp.Sanpada Railway Station Vashi Navi Mumbai, Mob : 9820707742
Mira Road	Shop No. 6, Jagannath Dham, Vinayak Nagar, Shree Vinayak Mandir Marg, Nr. Reliance Energy Coll Centre, Bhayander(W) 401101, Tel : 022-28183108
Kalyan	Shop No.1, Satyam Apartment, Bhanu Nagar, Near Bhanu Sagar Theatre, Station Road, Kalyan (WEST), Mob : 9819382052
Tirupati	19-3-13/M4, Behind Hero Honda Showroom, Renugunta Road, Tirupati - 517501, Tel : 0877-2282306/08
Ananthpur	Shop No.1, L.S.Towers, Opp.Lalithakala Parishad, Subash Road, Ananthapur - 515 001, Tel : 08554-241025, Mob : 9849987409
Kurnool	76-103-104, Vasavi Traders Godown, Bellary Road, Kurnool - 518 004, Mob : 9849987557
Trichi	5/2, Kumaran Plaza, Kumaran Nagar, Vayalur Main Road, Trichy -17, Tel : 0431-2771530 / 40 / 50, Mob : 3099564
Pondicherry	RS No. 70, Manaveli, Ariyankuppam, Pondicherry-605 007
Kumbakonam	Siva Complex, No. 29, Pettai Salai Karai Theru, Thanjavur Main Road, Tharasuram, Kumbakonam-612 001, Mob : 9443146973
Udaipur	101, Moti Magri Scheme, Udaipur, Tel : 0294-2419761
Kota	377-B, Near Radha Kishan Temple, Talwandi, Kota, Tel : 0744-2460902, Mob : 9829213510
Varanasi	Shree Ganga Keramos Compound, Lahartara Road, Shivdaspur, Manduadih, Varanasi, Tel : 0542-2373919, Mob : 3091773, 1774, 98398 000 00
Gorakhpur	C/179/301, Daudpur (Op.Kali Mandir), Gorakhpur,(U/P) Pin Code-273001, Tel : 0551-2202197, Mob : 9839800106
Allahabad	7-E/5 Tashkent Marg, Opp. St. Joseph College, Allahabad. (U. P), Pin. Code : 211001, Tel : 0532 - 2804216, Mob : 9839900104
Vijaywada	1st Floor, Yalamanchili Complex, Ring Road, Near Executive Club, Vijay wada - 520008, Tel : 0866-2450128, Mob : 3094526, 3094528
Rajahmundry	D.No: 79-5-7, Plot No: 44, Thilak Road, Beside State Bank Of Hyd, Rajahmundry, Mob : 9849987509
Vizag	D.No:14-1-99, Flat No: G-01, Horizon Enclave, Nowrozi Road, Maharani Peta, Vishakapatnam, Mob : 9849987507

WARRANTY

LG Electronics India Pvt. Ltd., warrants to the end-user customer that the LG refrigerator is free from defects in material or workmanship, under normal domestic use, for a period commencing on the date of purchase and enduring for the warranty period as stipulated, subject to the following conditions:

4 YEAR ADDITIONAL WARRANTY ON COMPRESSOR

The 4 year warranty on Compressor will continue even after the expiry of 1 year period from the date of purchase. This warranty covers Compressor only. Gas/Gas Charging will be charged to the customer. Gas charging is included only when compressor is defective & inoperative. During the additional warranty period, it does not cover any part such as condenser, freezer, capillary, suction line, overload protector, relay, thermostat etc.. Standard visiting charges will be applicable within the municipal limit of town where LG Electronics India Pvt. Ltd. (LGEIL) has its Authorized Service centre. Service outside municipal limit will attract to and fro traveling, other incidental expenses in addition to standard visiting charges, as prevailing from time to time. During the warranty period, only the parts replaced or repaired shall be free of costs, but service charges shall always be payable by the customer.

※ WARRANTY PERIOD

Refrigerator	Compressor	Linear Compressor (Selected Models Only)
One (1) year from the date of original retail purchase	Four (4) years from the date of original retail purchase	Ten (10) year from the date of original retail purchase
Parts and Labor	Parts only (Customer will be charged for labor)	

TERMS AND CONDITIONS

- Repairs & Replacements will be carried out either by the dealer from whom the set has been purchased, or through the Authorised Customer Care Centre with whom the set has been registered.
- For Units installed beyond the municipal limits of the jurisdiction of the authorised customer care centre, all expenses incurred in collecting the units or parts thereof from the company's customer care centre, as well as expenses incurred with deputising of service personnel/technicians towards conveyance and other incidentals etc. will be borne by the customer.
- The concerned customer care centre will advise the customer whether to effect the repair at site or at the customer care centre.
- While the company will make every effort to carry out repairs at the earliest, it however is made expressly clear that the company is under no obligation to do so in a specified period of time.
- The company or its authorised customer care centre/service dealer reserves the right to retain any part/s or components replaced at its discretion, in the event of a defect being noticed in the equipment during the warranty period.
- Warranty does not cover accessories external to the equipment supplied by the dealer, and replacement of light bulbs, filters, or any consumable parts.
- Noises associated with normal operation and failure to follow instructions found in the use and care and installation guides or operating the unit in an unsuitable environment will not be covered under this warranty.

Warranty voids if :

- The warranty card is not completed properly at the time of purchase.
- The completed warranty card is not presented to authorised personnel at the time of service of the product.
- The Refrigerator is not operated according to instructions given in the Operating Instructions booklet.
- Defects are caused by improper or reckless use, which shall be determined by company personnel.
- Any repair work is carried out by persons other than a authorised company personnel.
- Defects are caused due to causes beyond control like lightning, abnormal voltage, acts of God or while in transit to service centre or purchaser's residence.
- The warranty is not valid in case, the Serial Number is deleted, defected or altered.
- Damage to the refrigerator or any parts due to transportation or shifting is not covered by this warranty.
- This warranty automatically expires after 12 months of original date of purchase, even if the refrigerator may not be in use for any time for whatsoever reasons during the warranty period.

Customer Information Center

For any query related to the after sales service, please contact us on the numbers listed below :

City name	Contact No.
Bangalore	18001809999 (BSNL/MTNL Users)
Bhopal	
Calcutta	
Chennai	
Coimbatore	
Hyderabad	
Indore	
Jaipur	
Rajkot	
Surat	
Ahmedabad	
Delhi + NCR	
Lucknow	
Mumbai + Thane	
Nagpur	
Pune	

State	Contact No.
Andhra Pradesh	18001809999 (BSNL/MTNL Users)
Gujarat	
Karnataka	
MP	
Rajasthan	
Tamil Nadu	
UP - Eastern	
West Bengal	
Chandigarh	
Punjab	



LG Electronics India Pvt. Ltd.

Plot No.51, Udyog Vihar, Surajpur-Kasna Road
Greater Noida - 201 306 (UP)