

# Z650

## Motorcycle

---

# OWNER'S MANUAL

---

 Read this manual carefully. It contains safety information.

**Kawasaki**

# Quick Reference Guide

This Quick Reference Guide will assist you in finding the information you're looking for.

**SAFETY INFORMATION**

**GENERAL INFORMATION**

**HOW TO RIDE THE MOTORCYCLE**

**MAINTENANCE AND ADJUSTMENT**

**APPENDIX**

**MAINTENANCE RECORD**

A Table of Contents is included after the Foreword.

Whenever you see the symbols shown below, heed their instructions! Always follow safe operating and maintenance practices.

 **DANGER**

**DANGER** indicates a hazardous situation which, if not avoided, will result in death or serious injury.

 **WARNING**

**WARNING** indicates a hazardous situation which, if not avoided, could result in death or serious injury.

**NOTICE**

**NOTICE** is used to address practices not related to personal injury.

**NOTE**

○ *NOTE* indicates information that may help or guide you in the operation or service of the vehicle.

 **WARNING**

Engine exhaust, some of its constituents, and certain vehicle components contain or emit chemicals known to the State of California to cause cancer and birth defects or other reproductive harm.

***NOTICE***

**THIS PRODUCT HAS BEEN MANUFACTURED FOR USE IN A REASONABLE AND PRUDENT MANNER BY A QUALIFIED OPERATOR AND AS A VEHICLE ONLY.**

## Foreword

Congratulations on your purchase of a new Kawasaki motorcycle. Your new motorcycle is the product of Kawasaki's advanced engineering, exhaustive testing, and continuous striving for superior reliability, safety and performance.

**Please read this Owner's Manual carefully before riding** so that you will be thoroughly familiar with the proper operation of your motorcycle's controls, its features, capabilities, and limitations. This manual offers many safe riding tips, but its purpose is not to provide instruction in all the techniques and skills required to ride a motorcycle safely. Kawasaki strongly recommends that all operators of this vehicle enroll in a motorcycle rider training program to attain awareness of the mental and physical requirements necessary for safe motorcycle operation.

To ensure a long, trouble-free life for your motorcycle, give it the proper care and maintenance described in this manual. For those who would like more detailed information on their Kawasaki Motorcycle, a Service Manual is available for purchase from any authorized Kawasaki motorcycle dealer. The Service Manual contains detailed disassembly and maintenance information. Those who plan to do their own work should, of course, be competent mechanics and possess the special tools described in the Service Manual.

Keep this Owner's Manual aboard your motorcycle at all times so that you can refer to it whenever you need information.

This manual should be considered a permanent part of the motorcycle and should remain with the motorcycle when it is sold.

All rights reserved. No part of this publication may be reproduced without our prior written permission.

This publication includes the latest information available at the time of printing. However, there may be minor differences between the actual product and illustrations and text in this manual.

All products are subject to change without prior notice or obligation.

**KAWASAKI HEAVY INDUSTRIES, LTD.**  
**Motorcycle & Engine Company**

# Emission Control Information

To protect the environment in which we all live, Kawasaki has incorporated crankcase emission (1) and exhaust emission (2) control systems in compliance with applicable regulations of the United States Environmental Protection Agency and California Air Resources Board. Additionally, Kawasaki has incorporated an evaporative emission control system (3) in compliance with applicable regulations of the United States Environmental Protection Agency and California Air Resources Board.

## **1. Crankcase Emission Control System**

This system eliminates the release of crankcase vapors into the atmosphere. Instead, the vapors are routed through an oil separator to the intake side of the engine. While the engine is operating, the vapors are drawn into the combustion chamber, where they are burned along with the fuel and air supplied by the fuel injection system.

## **2. Exhaust Emission Control System**

This system reduces the amount of pollutants discharged into the atmosphere by the exhaust of this motorcycle. The fuel, ignition and exhaust systems of this motorcycle have been carefully designed and constructed to ensure an efficient engine with low exhaust pollutant levels. The exhaust system of this model motorcycle includes a catalytic converter system.

### **3. Evaporative Emission Control System**

The evaporative emission control system for this vehicle consists of low permeation fuel hoses and fuel tank.

### **3. Evaporative Emission Control System (California)**

Vapors caused by fuel evaporation in the fuel system are not vented into the atmosphere. Instead, fuel vapors are routed into the running engine to be burned, or stored in a canister when the engine is stopped.

### **High Altitude Performance Adjustment Information**

High Altitude adjustment is not required.

---

## Maintenance and Warranty

---

Proper maintenance is necessary to ensure that your motorcycle will continue to have low emission levels. This Owner's Manual contains those maintenance recommendations for your motorcycle. Those items identified by the Periodic Maintenance Chart are necessary to ensure compliance with the applicable standards.

As the owner of this motorcycle, you have the responsibility to make sure that the recommended maintenance is carried out according to the instructions in this Owner's Manual at your own expense.

The Kawasaki Limited Emission Control System Warranty requires that you return your motorcycle to an authorized Kawasaki dealer for remedy under warranty. Please read the warranty carefully, and keep it valid by complying with the owner's obligations it contains.

You should keep a maintenance record for your motorcycle. To assist you in keeping this record, we have provided space on pages 170 through 175 of this manual where an authorized Kawasaki dealer, or someone equally competent, can record the maintenance. You should also retain copies of maintenance work orders, bills, etc., as verification of this maintenance.

---

## **Tampering With Noise Control System Prohibited**

---

Federal law prohibits the following acts or the causing thereof: (1) the removal or rendering inoperative by any person other than for purposes of maintenance, repair, or replacement, of any device or element of design incorporated into any new vehicle for the purpose of noise control prior to its sale or delivery to the ultimate purchaser or while it is in use, or (2) the use of the vehicle after such device or element of design has been removed or rendered inoperative by any person.

Among those acts presumed to constitute tampering are the acts listed below:

- \* Replacement of the original exhaust system or muffler with a component not in compliance with Federal regulations.
- \* Removal of the muffler(s) or any internal portion of the muffler(s).
- \* Removal of the air box or air box cover.
- \* Modifications to the muffler(s) or air intake system by cutting, drilling, or other means if such modifications result in increased noise levels.

---

## TABLE OF CONTENTS

---

<b>SAFETY INFORMATION</b> .....	13	<b>GENERAL INFORMATION</b> .....	25
Read Owner's Manual .....	13	Specifications .....	25
Training .....	13	Serial Number Locations.....	30
Daily Checks and Periodic Maintenance .....	13	Location of Labels .....	31
Loading and Accessories Information.....	14	Location of Parts .....	39
Passenger .....	15	Meter Instruments .....	42
Baggage and Luggage .....	16	Indicators .....	43
Accessories .....	16	Speedometer/Tachometer .....	50
Other Load.....	17	Coolant Temperature Gauge .....	51
If You are Involved in an Accident....	18	Display Setting.....	52
Safe Operation.....	18	Features .....	62
Carbon Monoxide Hazard.....	18	Keys .....	65
Fueling.....	19	Ignition Switch/Steering Lock.....	65
Never Ride with Drugs or Alcohol.	19	Right Handlebar Switches.....	67
Protective Gear and Clothing .....	19	Left Handlebar Switches .....	68
Safe Riding Techniques.....	20	Brake Lever Adjuster.....	69
Additional Considerations for High Speed Operation .....	23	Clutch Lever Adjuster.....	70
		Fuel .....	71
		Fuel Requirements .....	71
		Filling the Tank.....	74

Side Stand .....	77	Throttle Control System .....	114
Seats .....	77	Idle Speed .....	117
Tie Hooks .....	79	Clutch .....	118
Tool Kit .....	80	Drive Chain .....	119
Rear View Mirrors .....	80	Brakes .....	124
Event Data Recorder.....	81	Brake Light Switches.....	126
<b>HOW TO RIDE THE MOTORCYCLE .</b>	<b>83</b>	Suspension System .....	128
Break-In .....	83	Front Fork .....	128
Starting the Engine .....	84	Rear Shock Absorber .....	129
Moving Off.....	86	Setting Table.....	131
Shifting Gears .....	87	Wheels .....	132
Braking.....	88	Battery.....	135
Anti-lock Brake System (ABS) .....	90	Headlight.....	140
Stopping the Engine.....	92	Fuses .....	143
Stopping the Motorcycle in an		General Lubrication.....	148
Emergency .....	92	Cleaning.....	148
Parking.....	93	General Precautions .....	148
<b>MAINTENANCE AND ADJUSTMENT</b>	<b>96</b>	Where to be Careful .....	153
Daily Checks .....	98	Washing Your Vehicle .....	153
Periodic Maintenance.....	101	<b>APPENDIX</b> .....	<b>155</b>
Engine Oil .....	106	Storage .....	155
Coolant.....	110	Troubleshooting Guide.....	158
Air Cleaner .....	113	Your Warranty/Owner Satisfaction ..	163

Reporting Safety Defects ..... 168  
Environmental Protection ..... 169

**MAINTENANCE RECORD ..... 170**

---

## SAFETY INFORMATION

---

### Read Owner's Manual

Read this Owner's Manual carefully before riding so that you will be thoroughly familiar with the proper operation of your motorcycle's controls, its features, capabilities, and limitations. This manual offers many safe riding tips, but its purpose is not to provide instruction in all of the techniques and skills required to ride a motorcycle safely.

### Training

Kawasaki strongly recommends that all operators of this vehicle complete a suitable motorcycle rider training program to learn the proper skills and techniques necessary for safe motorcycle operation.

### Daily Checks and Periodic Maintenance

It is important to keep your motorcycle properly maintained and in safe riding condition. Inspect your motorcycle before every ride and carry out all periodic maintenance. See the Daily Checks section and the Periodic Maintenance section in the MAINTENANCE AND ADJUSTMENT chapter for more information.

**WARNING**

**Failure to perform these checks or to correct a problem before operation may result in serious damage or an accident. Always perform daily checks before operation.**

## 14 SAFETY INFORMATION

To ensure your motorcycle is serviced using the latest servicing information, it is recommended that an authorized Kawasaki Dealer performs the periodic maintenance as directed in the Owner's Manual.

If you notice any irregular operating condition, have your motorcycle thoroughly checked at an authorized Kawasaki dealer as soon as possible.

## Loading and Accessories Information

### **WARNING**

**Incorrect loading, improper installation or use of accessories, or modification of your motorcycle may result in an unsafe riding condition. Before you ride the motorcycle, make sure it is not overloaded and that you have followed these instructions.**

#### **Maximum Load**

Weight of rider, passenger, baggage, and accessories must not exceed 200 kg (441 lb).

With the exception of genuine Kawasaki Parts and Accessories, Kawasaki has no control over the design or application of accessories. In some cases, improper installation

or use of accessories, or motorcycle modification, will void the motorcycle warranty; can negatively affect performance, stability and safety; and can even be illegal.

In selecting and using accessories, and in loading the motorcycle, you are personally responsible for your own safety and the safety of other persons involved.

### NOTE

○ *Kawasaki Parts and Accessories have been specially designed for use on Kawasaki motorcycles. We strongly recommend that all parts and accessories you add to your motorcycle be genuine Kawasaki components.*

Because a motorcycle is sensitive to changes in weight and aerodynamic forces, you must take extreme care in carrying cargo, passengers and/or in

fitting additional accessories. The following general guidelines have been prepared to assist you in making your determinations.

---

### Passenger

---

1. Never carry more than one passenger.
2. The passenger should only sit on the pillion.
3. Any passenger should be thoroughly familiar with motorcycle operation. The passenger can affect control of the motorcycle by improper positioning during cornering and sudden movements. It is important that the passenger sits still while the motorcycle is in motion and not interfere with the operation of the motorcycle. Do not carry animals on your motorcycle.

## 16 SAFETY INFORMATION

4. Do not carry passengers unless passenger footpegs are installed. Instruct any passenger before riding to keep his or her feet on the passenger footpegs and hold on to the operator or seat strap. Do not carry a passenger unless he or she is tall enough to reach the footpegs with their feet.

---

### Baggage and Luggage

---

1. All baggage should be carried as low as possible to reduce the effect on the motorcycle's center of gravity. Baggage weight should also be distributed equally on both sides of the motorcycle. Avoid carrying baggage that extends beyond the rear of the motorcycle.
2. Baggage should be securely attached. Make sure that the baggage

will not move around while you are riding. Recheck baggage security as often as possible (not while the motorcycle is in motion) and adjust as necessary.

3. Do not carry heavy or bulky items on a luggage rack. It is designed for light items, and overloading can affect handling due to changes in weight distribution and aerodynamic forces.

---

### Accessories

---

1. Do not install accessories or carry baggage that impairs the performance of the motorcycle. Make sure that you have not adversely affected any lighting components, road clearance, banking capability (i.e., lean angle), control operation, wheel travel, front fork movement,

or any other aspects of the motorcycle's operation.

2. Weight attached to the handlebars or front fork will increase the mass of the steering assembly and can result in an unsafe riding condition.
3. Fairings, windshields, backrests, and other large items have the capability of adversely affecting stability and handling of the motorcycle, not only due to their weight, but also due to the aerodynamic force acting on these surfaces while the motorcycle is in operation. Poorly designed or installed items can result in an unsafe riding condition. Lugs are provided on the swingarm to attach accessory rear stand adapters. Always remove the rear stand adapters before riding or sitting on the machine to prevent possible damage to the muffler or swingarm.

---

## Other Load

---

1. This motorcycle is not intended to be equipped with a sidecar or to be used to tow any trailers or other vehicles. Kawasaki does not manufacture sidecars or trailers for motorcycles and cannot predict the effects of such accessories on handling or stability, but can only warn that the effects can be adverse and that Kawasaki cannot assume responsibility for the results of such unintended use of the motorcycle.
2. Furthermore, any adverse effects on motorcycle components caused by the use of such accessories will not be remedied under warranty.

### If You are Involved in an Accident

Make sure of your own safety first. Determine the severity of any injuries and call for emergency assistance if needed. Always follow applicable laws and regulations if any other person, vehicle or property is involved.

Do not attempt to continue riding without first evaluating your motorcycle's condition. Inspect for fluid leaks, check critical nuts and bolts, and check the handlebars, control levers, brakes, and wheels for damage and proper function. Ride slowly and cautiously - your motorcycle may have suffered damage that is not immediately apparent. Have your motorcycle thoroughly checked at a Kawasaki dealer as soon as possible.

### Safe Operation

The following should be carefully observed for safe and effective vehicle operation.

---

### Carbon Monoxide Hazard

---

#### **DANGER**

**Exhaust gas contains carbon monoxide, a colorless, odorless poisonous gas. Inhaling carbon monoxide can cause serious brain injury or death. DO NOT run the engine in enclosed areas. Operate only in a well-ventilated area.**

---

## Fueling

---

 **WARNING**

**Gasoline is extremely flammable and can be explosive under certain conditions. To avoid a possible fire or explosion, turn the ignition switch off. Do not smoke. Make sure the area is well ventilated and free from any source of flame or sparks; this includes any appliance with a pilot light.**

---

## Never Ride with Drugs or Alcohol

---

Alcohol and drugs impair your judgment and reaction time. Never consume alcohol or drugs before or while riding motorcycles.

---

## Protective Gear and Clothing

---

### *Helmet*

Kawasaki strongly recommends both the operator and passenger wear a DOT-approved helmet even if this is not a legal requirement.

- Make sure that your helmet fits correctly and is properly fastened.
- Choose a motorcycle helmet that meets DOT safety standards. Ask your motorcycle dealer to advise you if necessary.

## 20 SAFETY INFORMATION

### ***Eye Protection***

Always use eye protection. If your helmet does not have a visor installed, wear goggles.

### ***Gloves***

Wear gloves which have suitable protection for your hands, especially against abrasion.

### ***Clothing***

Wear the riding wear which have protectors for each parts of the body (chest, shoulders, back, elbows and knees, etc.) as much as possible, or wear protectors for them.

- Always wear a long-sleeved jacket and long trousers which are abrasion resistant and keep you warm.
- Wear clothing that allows freedom of movement.
- Avoid wearing clothes which have loose cuffs or other fastenings which

could interfere with the controls of your motorcycle.

- Wear bright, highly visible clothing.

### ***Boots***

Wear proper protective boots that fit properly and do not interfere with gear shifting or braking.

---

## **Safe Riding Techniques**

---

### ***Keep Hands on Handlebars***

When riding always keep both hands on the handlebars and both feet on the footpegs. Removing your hands from the handlebars or feet from the footpegs while riding can be hazardous. If you remove even one hand or foot, you reduce your ability to control the motorcycle.

### ***Look Over Your Shoulder***

Before changing lanes, look over your shoulder to make sure the way is clear. Do not rely solely on the rear view mirror; you may misjudge a vehicle's distance and speed, or you may not see it at all.

### ***Accelerate and Brake Smoothly***

In general your actions should be smooth as sudden acceleration, braking or turning may cause loss of control, especially when riding in wet conditions or on loose road surfaces, when the ability to maneuver will be reduced.

### ***Select Correct Gear Speeds***

When going up steep slopes, shift to a lower gear so that there is power to spare rather than overloading the engine.

### ***Use Both Front and Rear Brakes***

When applying the brakes, use both the front and rear brakes. Applying only one brake for sudden braking may cause the motorcycle to skid and lose control.

### ***Use Engine Brake***

When going down long slopes, help control vehicle speed by closing the throttle so that the engine can act as an auxiliary brake. Use the front and rear brakes for primary braking.

### ***Riding in Wet Conditions***

Rely more on the throttle to control vehicle speed and less on the front and rear brakes. The throttle should also be used judiciously to avoid skidding the rear wheel from too rapid acceleration or deceleration.

Braking performance is also reduced in wet conditions. Carefully ride at a

## 22 SAFETY INFORMATION

slow speed and apply the brakes several times to help dry and restores them to normal operating performance.

Lubricate the drive chain after wet-weather riding to prevent rust and corrosion.

### ***Ride Prudently***

Riding at the proper speed and avoiding unnecessarily fast acceleration are important not only for safety and low fuel consumption but also for long vehicle life and quieter operation.

### ***Riding on Rough Roads***

Exercise caution, slow down, and grip the fuel tank with the knees for better stability.

### ***Acceleration***

When quick acceleration is necessary to pass another vehicle, shift to a lower gear to obtain the necessary power.

### ***Downshifting***

To avoid engine damage and rear wheel lock-up do not downshift at high rpm.

### ***Avoid Unnecessary Weaving***

Unnecessary weaving jeopardizes the safety of both the rider and other motorists.

---

## Additional Considerations for High Speed Operation

---

 **WARNING**

Handling characteristics of a motorcycle at high speeds may vary from those you are familiar with at legal highway speeds. Do not attempt high speed operation unless you have received sufficient training and have the required skills. Do not operate at high speeds on public roads.

### ***Brakes***

The importance of the brakes, especially during high speed operation, cannot be overemphasized. Check to

see that they are correctly adjusted and functioning properly.

### ***Steering***

Looseness in the steering can cause loss of control. Check to see that the handlebars turn freely but has no play.

### ***Tires***

High speed operation is hard on tires, and good tires are crucial for safe riding. Examine their overall condition, inflate them to the proper pressure, and check the wheel balance.

### ***Fuel***

Have sufficient fuel for the high fuel consumption during high speed operation.

### ***Engine Oil***

To avoid engine seizure and resulting loss of control, make sure that the oil level is at the upper level line.

## 24 SAFETY INFORMATION

### ***Coolant***

To avoid overheating, check that the coolant level is at the upper level line.

### ***Electrical Equipment***

Make sure that the headlight, tail/brake light, turn signals, horn, etc., all work properly.

### ***Miscellaneous***

Make sure that all nuts and bolts are tight and that all safety related parts are in good condition.

---

# GENERAL INFORMATION

---

## Specifications

### PERFORMANCE

Minimum Turning Radius      2.6 m (8.5 ft)

### DIMENSIONS

Overall Length                      2 055 mm (80.91 in.)

Overall Width                        775 mm (30.5 in.)

Overall Height                       1 080 mm (42.52 in.)

Wheelbase                            1 410 mm (55.51 in.)

Road Clearance                      130 mm (5.12 in.)

Curb Mass:

ER650G                                184 kg (406 lb)

(CAL)                                    185 kg (408 lb)

ER650H                                186 kg (410 lb)

(CAL)                                    187 kg (412 lb)

## 26 GENERAL INFORMATION

### ENGINE

Type	DOHC, 2-cylinder, 4-stroke, liquid-cooled
Displacement	649 cm <sup>3</sup> (39.6 cu in.)
Bore x Stroke	83.0 x 60.0 mm (3.27 x 2.36 in.)
Compression Ratio	10.8:1
Starting System	Electric starter
Cylinder Numbering Method	Left to right, 1-2
Firing Order	1-2
Fuel System	FI (Fuel Injection)
Ignition System	Battery and coil (transistorized ignition)
Ignition Timing (Electronically advanced)	10° BTDC @1 300 r/min (rpm) ~ 47° BTDC @6 000 r/min (rpm)
Spark Plug:       Type	NGK CR9EIA-9
Gap	0.8 ~ 0.9 mm (0.031 ~ 0.035 in.)
Lubrication System	Forced lubrication (Semi-dry sump)

Engine Oil:	Type	API SG, SH, SJ, SL, or SM with JASO MA, MA1 or MA2
	Viscosity	SAE 10W-40
	Capacity	2.3 L (2.4 US qt)
Coolant Capacity		1.2 L (1.3 US qt)

## TRANSMISSION

Transmission Type		6-speed, constant mesh, return shift
Clutch Type		Wet, multi disc
Driving System		Chain drive
Primary Reduction Ratio		2.095 (88/42)
Final Reduction Ratio		3.067 (46/15)
Overall Drive Ratio		5.473 (Top gear)
Gear Ratio:	1st	2.438 (39/16)
	2nd	1.714 (36/21)
	3rd	1.333 (32/24)
	4th	1.111 (30/27)
	5th	0.966 (28/29)
	6th	0.852 (23/27)

## 28 GENERAL INFORMATION

### FRAME

Caster		24°
Trail		100 mm (3.94 in.)
Tire Size:	Front	120/70ZR17 M/C (58W)
	Rear	160/60ZR17 M/C (69W)
Rim Size:	Front	17M/C × MT3.50
	Rear	17M/C × MT4.50
Fuel Tank Capacity		15 L (4.0 US gal)
Brake Fluid:	Front	DOT4
	Rear	DOT4

### ELECTRICAL EQUIPMENT

Battery		12 V 8.6 Ah (10 HR)
Headlight:	High Beam	12 V 60 W
	Low Beam	12 V 55 W
Brake/Tail Light		LED

CAL: California model

Even if one of LED (Light Emitting Diode) brake/tail light does not go on, consult with an authorized Kawasaki dealer.

### **Brake/Tail Light**

The brake/tail light goes on as below.

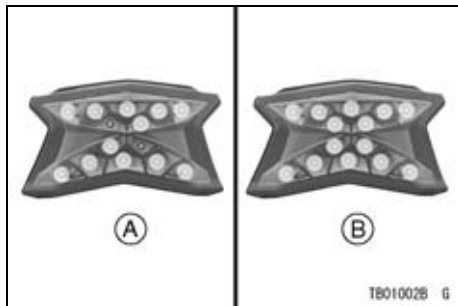

**A. When the ignition switch is turned on.**

**B. When the brakes are applied.**

When the ignition switch is turned on, some LED does not go on, however, it is normal.

Specifications are subject to change without notice.

### Serial Number Locations

The engine and frame serial numbers are used to register the motorcycle. They are the only means of identifying your particular machine from others of the same model type. These serial numbers may be needed by your dealer when ordering parts. In the event of theft, the investigating authorities will require both numbers as well as the model type and any peculiar features of your machine that can help them identify it.

#### Engine No.

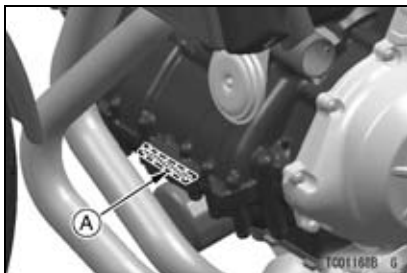

A. Engine Number

#### Frame No.

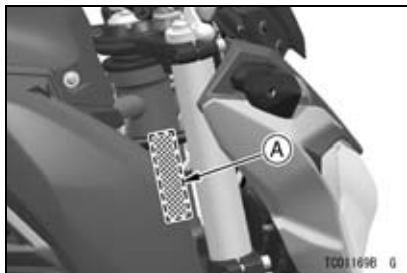

A. Frame Number

## Location of Labels

All warning labels which are on your vehicle are repeated here. Read labels on your vehicle and understand them thoroughly. They contain information which is important for your safety and the safety of anyone else who may operate your vehicle. Therefore, it is very important that all warning labels be on your vehicle in the locations shown. If any label is missing, damaged, or worn, get a replacement from your Kawasaki dealer and install it in the correct position.

### NOTE

- *The sample warning labels in this section have part numbers to help*

*you and your dealer obtain the correct replacement.*

- *Refer to the actual vehicle label for model specific data grayed out in the illustration.*



**1. Brake Fluid (Front)**

## 32 GENERAL INFORMATION

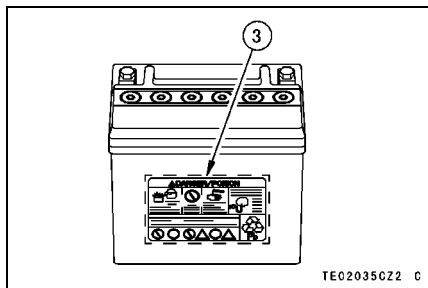
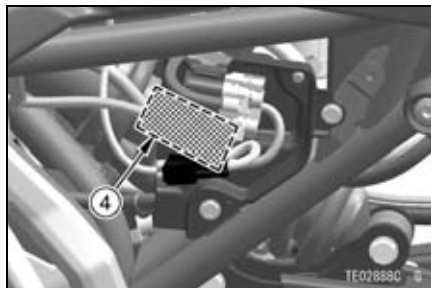

- 2. Brake Fluid (Rear)
- 3. Battery Poison/Danger
- 4. Rear Shock Absorber Warning

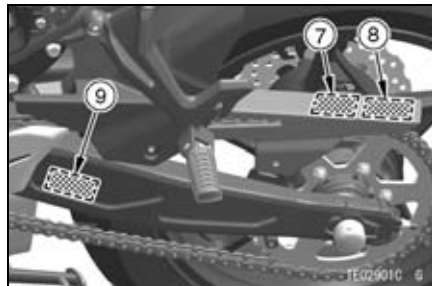
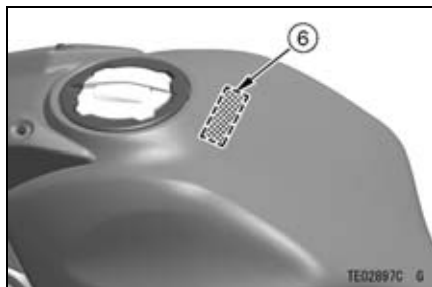
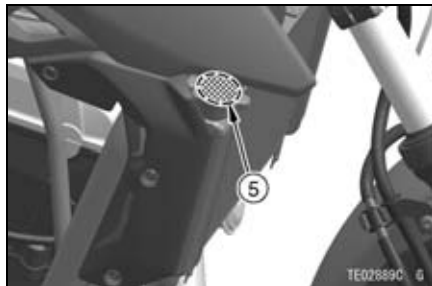

- 5. Radiator Cap Danger
- \*6. Fuel Level
- 7. Important Drive Chain Information
- 8. Tire and Load Data
- 9. Noise Emission Control Information

\*: only on California model

## 34 GENERAL INFORMATION

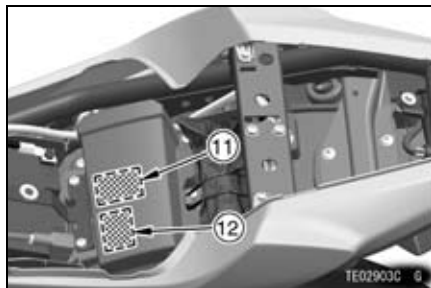
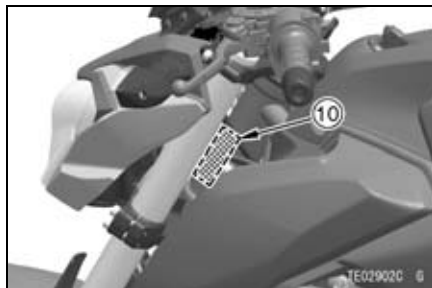

- 10. Weight and Manufacture
- \*11. Vacuum Hose Routing Diagram
- 12. Vehicle Emission Control Information

\*: only on California model

1)

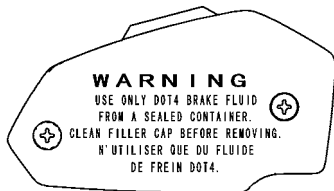

TE03841BN9 C

3)



TE03498E S

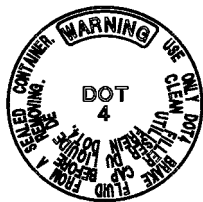

2)



TE03879DN9 C

## 36 GENERAL INFORMATION

4)

 <b>WARNING</b>
This unit contains high pressure nitrogen gas. Mishandling can cause explosion. ● Do not incinerate, puncture or open.
 <b>AVERTISSEMENT</b>
Cette unité contient de l'azote à haute pression. Une mauvaise manipulation peut entraîner d'explosion. ● Ne pas brûler ni perforer ni ouvrir.
 <b>警告</b>
高压窒素ガス入りです。 取り扱いを誤ると爆発する恐れがあります。 ● 火中への投入、穴あけ、分解はしないでください。

TE03460DN7 C

5)



TE03B012 P

6) only on California model



56071-0158

TE03142C S

7)

**CHAIN INFORMATION**

Drive chain slack should be checked before each ride and adjusted if outside of normal adjustment range (20-30 mm, 0.8-1.2 in). To check slack, measure slack midway between the sprockets while the motorcycle is on the side stand. See Owner's Manual for additional drive chain information.



56033-0850

TE03468E S

9)

**MOTORCYCLE NOISE EMISSION CONTROL INFO.**

THIS MOTORCYCLE MEETS EPA NOISE EMISSION REQUIREMENTS BY THE FEDERAL TEST PROCEDURE. MODIFICATIONS WHICH CAUSE THIS MOTORCYCLE TO EXCEED FEDERAL NOISE STANDARDS ARE PROHIBITED BY FEDERAL LAW. SEE OWNER'S MANUAL. ( )  
 MODEL SPECIFIC CODE: ( )  
 SEE VEHICLE IDENTIFICATION NUMBER ON STEERING HEAD NOISE LIMIT/CLOSING RPM: ( )DBA/( )RPM

TE03304D S

8)

**WARNING**

Use of tires with improper inflation or excessive wear, unsuitable replacement tires or overloading can result in a loss of control causing serious bodily injury. See Owner's Manual for additional information.

**TIRE AND LOAD DATA**

	Alt. Pressure (kPa)	Size & Max. Type (Load Index, Max. Load)	Min. Tire Load (kg)
100°C (86 to 200 in. Hg) (693-267)	70 kPa (10.14 bar, 12.53 psi)	120/70ZR17 M/C 80W SPORTMAX 73RAD	1.1mm (0.04 in)
	80 kPa (11.61 bar, 14.76 psi)	120/70ZR17 M/C 80W SPORTMAX 73RAD	1.1mm (0.04 in)
100°C (86 to 200 in. Hg) (693-267)	80 kPa (11.61 bar, 14.76 psi)	120/70ZR17 M/C 80W SPORTMAX 73RAD	1.1mm (0.04 in)
	80 kPa (11.61 bar, 14.76 psi)	120/70ZR17 M/C 80W SPORTMAX 73RAD	1.1mm (0.04 in)

56053-1400

TE03756E S

10)

MFD. BY KAWASAKI HEAVY INDUSTRIES, LTD.  
 DATE: ( ) THIS VEHICLE CONFORMS TO ALL APPLICABLE FEDERAL MOTOR VEHICLE SAFETY STANDARDS IN EFFECT ON THE DATE OF MANUFACTURE SHOWN ABOVE. GVWR ( ) LBS.  
 GAWR F ( ) LBS. WITH ( )  
 TIRE, ( ) RIM, AT ( ) PSI, COLD.  
 GAWR R ( ) LBS. WITH ( )  
 TIRE, ( ) RIM, AT ( ) PSI, COLD.  
 ( )  
 MOTOR CYCLE ( ) MADE IN THAILAND

TE034420N9 C

## 38 GENERAL INFORMATION

### 11) only on California model

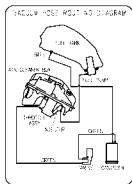

59465-1871

TE03291E S

### 12) only on California model

VEHICLE EMISSION CONTROL INFORMATION		59465-1871
ENGINE FAMILY CODE	PERMATION FAMILY	
ENGINE MODEL	CONTROL SYSTEM	
DISPLACEMENT		
TUNE UP SPECIFICATIONS		
IGNITION TIMING	NO ADJUSTMENT	
VALVE CLEARANCE	NO ADJUSTMENT	
SPARK PLUGS	EQUAL SPARK PLUG GAP	
FUEL	GASOLINE WITH ANTIKNOCK INDEX	
ENGINE OIL	SERVICE RATING: (API) SE, SF, SA, SL OR SM	
VELOCITY: SAE 10W-40		
SEE THE OWNER'S MANUAL FOR ENGINE OIL INFORMATION.		
THIS VEHICLE COMPLIES TO U.S. EPA AND CALIFORNIA REGULATIONS APPLICABLE TO 1994 MODEL YEAR NEW MOTORCYCLES AND IS CERTIFIED TO EUROPEAN UNION ENGINE FAMILY EXHAUST EMISSION STANDARD IN U.S. EPA.		
KAWASAKI MOTORS ENTERPRISE (THAILAND) CO., LTD.		

TE03270E S

### 12)

VEHICLE EMISSION CONTROL INFORMATION		59465-1871
ENGINE FAMILY CODE	PERMATION FAMILY	
ENGINE MODEL	CONTROL SYSTEM	
DISPLACEMENT		
TUNE UP SPECIFICATIONS		
IGNITION TIMING	NO ADJUSTMENT	
VALVE CLEARANCE	NO ADJUSTMENT	
SPARK PLUGS	EQUAL SPARK PLUG GAP	
FUEL	GASOLINE WITH ANTIKNOCK INDEX	
ENGINE OIL	SERVICE RATING: (API) SE, SF, SA, SL OR SM	
VELOCITY: SAE 10W-40		
SEE THE OWNER'S MANUAL FOR ENGINE OIL INFORMATION.		
THIS VEHICLE COMPLIES TO U.S. EPA REGULATIONS APPLICABLE TO 1994 MODEL YEAR NEW MOTORCYCLES AND IS CERTIFIED TO AN EUROPEAN EMISSION STANDARD IN U.S. EPA.		
KAWASAKI MOTORS ENTERPRISE (THAILAND) CO., LTD.		

TE03269E S

## Location of Parts

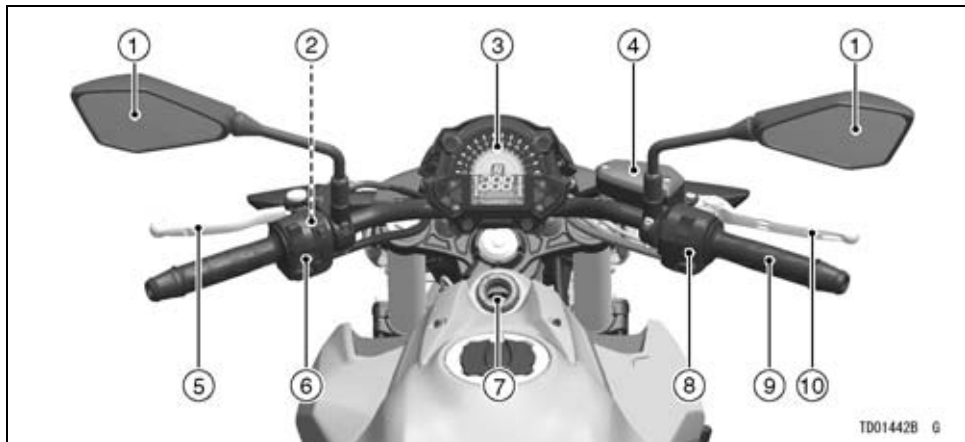

1. Rear View Mirrors
2. Starter Lockout Switch
3. Meter Instrument
4. Brake Fluid Reservoir (Front)
5. Clutch Lever

6. Left Handlebar Switches
7. Ignition Switch/Steering Lock
8. Right Handlebar Switches
9. Throttle Grip
10. Front Brake Lever

## 40 GENERAL INFORMATION

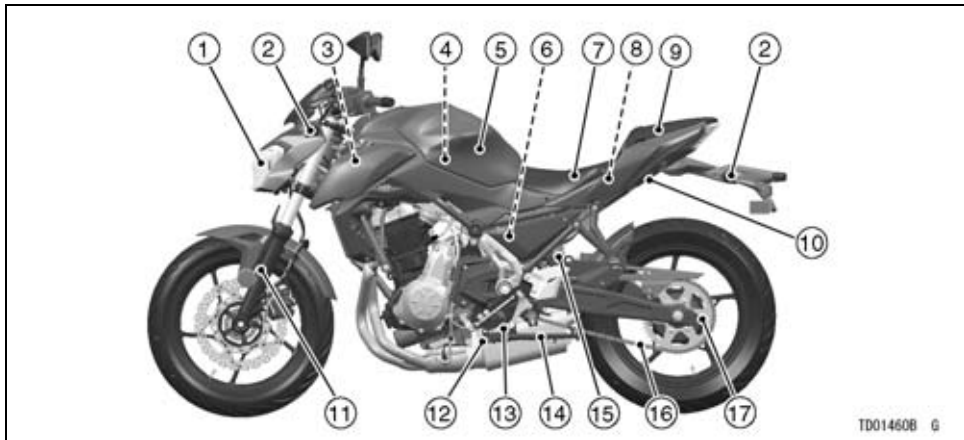

TD01460B G

- |                            |                         |
|----------------------------|-------------------------|
| 1. Headlight               | 10. Seat Lock           |
| 2. Turn Signal Lights      | 11. Front Fork          |
| 3. Fuse Box                | 12. Side Stand Switch   |
| 4. Air Cleaner             | 13. Shift Pedal         |
| 5. Fuel Tank               | 14. Side Stand          |
| 6. Spring Preload Adjuster | 15. Rear Shock Absorber |
| 7. Rider's Seat            | 16. Drive Chain         |
| 8. Tool Kit                | 17. Chain Adjuster      |
| 9. Passenger's Seat        |                         |

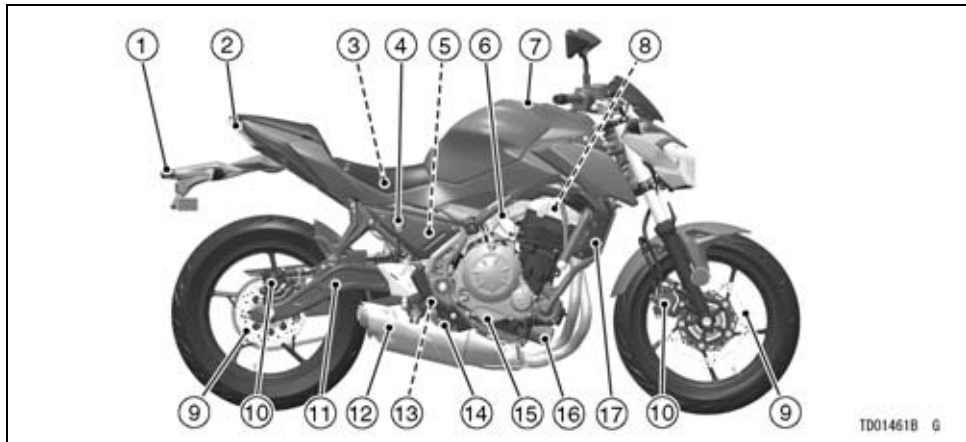

TD01461B G

- |                                 |                                 |
|---------------------------------|---------------------------------|
| 1. License Plate Light          | 10. Brake Calipers              |
| 2. Tail/Brake Light             | 11. Swingarm                    |
| 3. Battery                      | 12. Muffler                     |
| 4. Brake Fluid Reservoir (Rear) | 13. Rear Brake Light Switch     |
| 5. Coolant Reserve Tank         | 14. Brake Pedal                 |
| 6. Idle Adjusting Screw         | 15. Oil Level Inspection Window |
| 7. Fuel Tank Cap                | 16. Oil Filter                  |
| 8. Spark Plugs                  | 17. Radiator                    |
| 9. Brake Discs                  |                                 |

## Meter Instruments

1. Tachometer
2. Left Meter Button
3. Right Meter Button
4. Multifunction Meter
5. Tachometer Gauge and Shift-up Indicator
6. Economical Riding Indicator
7. Coolant Temperature Gauge
8. Gear Position Indicator
9. Speedometer
10. Fuel Gauge
11. Multifunction Display
  - Odometer
  - Trip Meter A/B
  - Current Mileage/Average Mileage/Cruising Range
  - Clock

When the ignition switch is turned on, all LCD functions are shown for a few seconds, then the multifunction meter turns to operational mode.

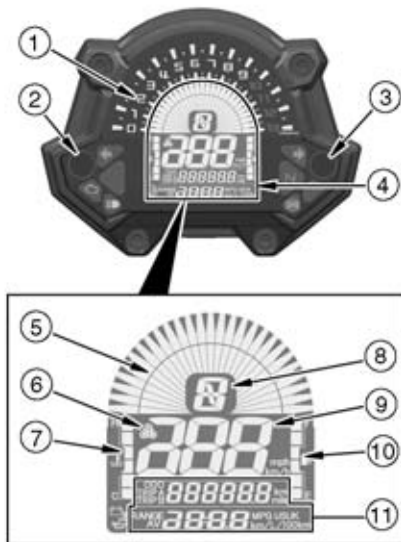

## Indicators

1.  Left Turn Signal Indicator (Green)
2.  Warning Indicator (Red)
3.  Engine Warning Indicator (Yellow)
4.  High Beam Indicator (Blue)
5.  Fuel Level Warning Indicator
6.  Right Turn Signal Indicator (Green)
7.  Neutral Indicator (Green)
8.  ABS Indicator (Yellow) (ABS model)
9.  Battery Warning Indicator
10.  Coolant Temperature Warning Indicator
11.  Oil Pressure Warning Indicator

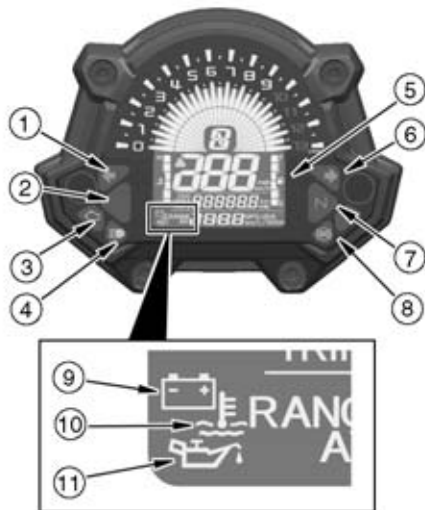

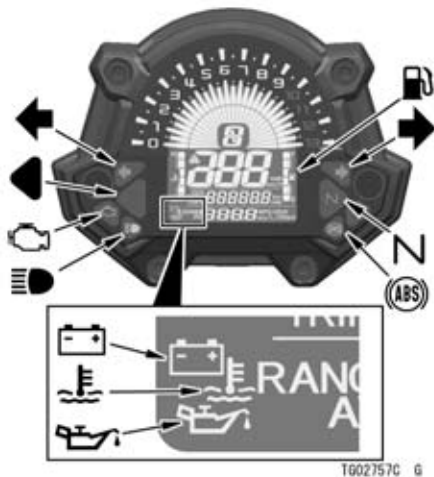
**Indicator Initial Operation**

When the ignition switch is turned on, all indicators go on/off as shown in the

table. If any indicator does not operate as shown, have it checked by an authorized Kawasaki dealer.

ON			Indicators
<input type="checkbox"/>	<input type="checkbox"/>	<input type="checkbox"/>	<b>N</b> *
<input type="checkbox"/>	<input type="checkbox"/>	<input checked="" type="checkbox"/>	
<input type="checkbox"/>	<input checked="" type="checkbox"/>	<input checked="" type="checkbox"/>	
<input checked="" type="checkbox"/>	<input checked="" type="checkbox"/>	<input checked="" type="checkbox"/>	

ON: When ignition switch is turned on.

: After a few seconds

: When engine starts.

: Goes on.



: Goes off.

\* : goes off shortly after the motorcycle starts moving.



### ***When Warning Indicators Go On or Blink***



When warning indicators appear, there could be a problem with vehicle function. Follow actions in the table after stopping the vehicle in a safe place.

\*: The numbers in this column corresponds to reference numbers on page 43.

*No.	Indicators	Status	Actions
8		ON* <sup>1</sup>	The ABS has malfunctioned. ABS will not work but conventional brakes function. Have the ABS checked by an authorized Kawasaki dealer.
3		ON	The DFI system has malfunctioned. Have it checked by an authorized Kawasaki dealer.
2 9		ON	These indicators go on if the battery voltage is less than 11.0 V or more than 16.0 V. If the voltage is less than 11.0 V, charge the battery. If the voltage is more than 16.0 V, or if indicators still go on after charging the battery, have the battery and/or charging system checked by an authorized Kawasaki dealer.

## 46 GENERAL INFORMATION

*No.	Indicators	Status	Actions
2 11		ON	These indicators go on whenever the oil pressure is dangerously low or the ignition switch is in the "ON" position with the engine not running. If these indicators go on when the engine speed is above idle, stop the engine immediately and check the engine oil level. If the amount of engine oil is insufficient, add engine oil. If the oil level is good, have the engine checked by an authorized Kawasaki dealer.
2 10		ON	These indicators go on whenever the coolant temperature rises to about 115°C (239°F). Refer to the Coolant Temperature Gauge section for more information and follow instructions in it.

*No.	Indicators	Status	Actions
5		Blink	The lowest segment and fuel level warning indicator blink in the multifunction display when approximately 3.8 L (1.0 US gal) of usable fuel remains. Refuel at the earliest opportunity. If the vehicle is on the side stand, the warning indicator cannot estimate the amount of fuel in the tank. Stand the vehicle upright to check the fuel level.
		Blink (including all segments)	The fuel level warning system has malfunctioned. Have the fuel level warning system checked by an authorized Kawasaki dealer.



## 48 GENERAL INFORMATION

\*1: ABS indicator may go on:

- After continuous riding on a rough road.
- When the engine is started with the stand raised and the transmission engaged, and the rear wheel turns.
- When accelerating so abruptly that the front wheel leaves the ground.
- When the ABS has been subjected to strong electrical interference.
- When tire pressure is abnormal. Adjust tire pressure.
- When a tire different in size from the standard size is being used. Replace with standard size.
- When the wheel is deformed. Replace the wheel.

If this happens, first turn the ignition switch off, and then back on, and ride the motorcycle at 5 km/h (3.1 mph) or more. The ABS indicator should then go off. If it does not, have the ABS checked by an authorized Kawasaki dealer.

## Other Indicators

*No.	Indicators	Status
1		When the turn signal switch is pushed to the left, this indicator blinks.
6		When the turn signal switch is pushed to the right, this indicator blinks.
4		When the headlight is on high beam, this indicator goes on.
7	<b>N</b>	When the transmission is in neutral, this indicator goes on.

## Speedometer/Tachometer



- A. Tachometer
- B. Tachometer Gauge and Shift-up Indicator
- C. Red Zone
- D. Speedometer

### Speedometer

The speedometer is digital and can be set for km/h or mph.

The unit setting can be changed according to local regulations. Make sure

the unit setting (km/h or mph) is correctly displayed before riding.

Refer to the Unit Setting in the Display Setting section.

### Tachometer

The tachometer shows the engine speed in revolutions per minute (r/min, rpm).

## NOTICE

**Engine speed should not be allowed to enter the red zone; operation in the red zone will overstress the engine and may cause serious engine damage.**

When the ignition switch is turned on, the tachometer segment(s) momentarily go from the minimum to the maximum reading, then go back the minimum reading to check its operation. If

the tachometer does not operate correctly, have it checked by an authorized Kawasaki dealer.

The tachometer also serves as the shift-up indicator.

### ***Shift-up Indicator***

The shift-up indicator can be used to indicate the timing for next up shift by blinking the shift-up indicator once a pre-set engine speed is reached.

#### ***Shift-up Indicator Setting***

- Refer to the Shift-up Indicator Setting in the Display Setting section.

---

## **Coolant Temperature Gauge**

---

The coolant temperature gauge indicates temperature of the engine coolant by the number of segments displayed.

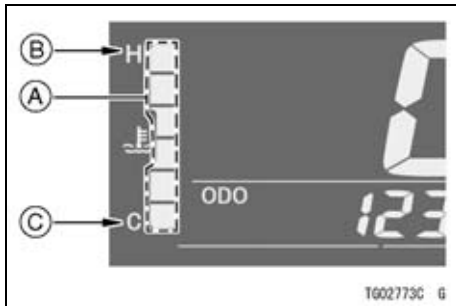

- A. Segments**
- B. H (Hot)**
- C. C (Cold)**

If the coolant temperature rises to above 115°C (239°F), All segments go on, and the warning indicator and coolant temperature warning indicator go on. This warns the operator that the coolant temperature is high. Stop the engine and check the coolant level in the reserve tank after the engine cools down. If the amount of the coolant is

## 52 GENERAL INFORMATION

insufficient, add coolant to the reserve tank. If the coolant level is good, have the cooling system checked by an authorized Kawasaki dealer.

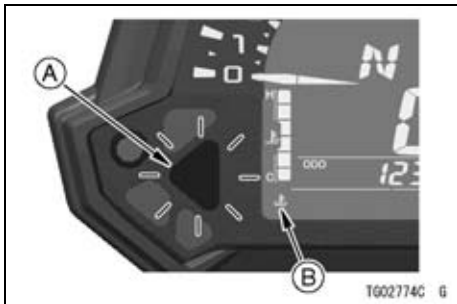

- A. Warning Indicator (Red)
- B. Coolant Temperature Warning Indicator

### **NOTICE**

**Stop the engine if the warning indicator and coolant temperature warning indicator go on. Prolonged engine operation will result in severe engine damage from overheating.**

---

### Display Setting

---

#### *Multifunction Display*

### **⚠ WARNING**

**For safety, do not operate the meter buttons while riding the motorcycle.**

- Push the left meter button or right meter button to select the display

modes. The display modes can be shifted in the following order.

**NOTE**

- *The multifunction display is displayed in the unit depending on the unit mode setting.*

## 54 GENERAL INFORMATION

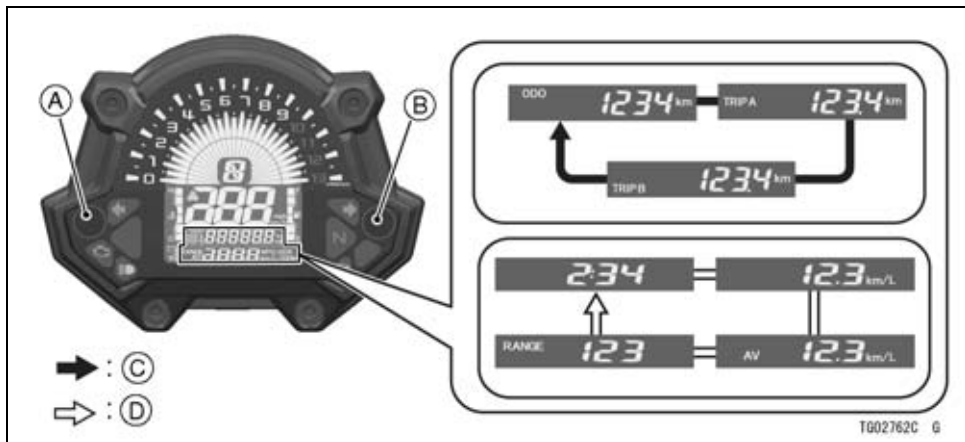

- A. Left Meter Button
- B. Right Meter Button
- C. Flow when pushing left meter button
- D. Flow when pushing right meter button

## Odometer

The odometer shows the total distance. This meter cannot be reset.



### NOTE

- *When the figures come to 999999, the display is stopped and locked.*

## Trip Meter



To reset the trip meter:

- Push the left meter button to select the trip meter A or B.

- Push the left meter button and hold it in until the display turns to 0.0.

### NOTE

- *When the trip meter reaches 9999.9 while riding, the meter resets to 0.0 and continues counting.*

## Current Mileage

The current mileage display is renewed every 4 seconds.



### NOTE

- *When the ignition switch is turned on, the numerical value shows "– –.–." After a few seconds of riding the numerical value is displayed.*

## 56 GENERAL INFORMATION

### Average Mileage

This display shows the average fuel consumption from the reset. The average mileage display is renewed every 5 seconds.



To reset the average mileage:

- Push the right meter button and hold it in until the average mileage values resets to “— . —.”

### NOTE

- When the battery is disconnected, the average mileage resets to “— . —.”
- After resetting the average mileage, the numerical value is not displayed until the vehicle has travelled 100 m (328 ft).

### Cruising Range

This display shows the cruising range by numerical value, and indicates the cruising range from the remaining fuel in the fuel tank. This cruising range display is renewed every 20 seconds.



### NOTE

- The cruising range value is no longer shown if the fuel level gets too low after the fuel level warning indicator starts blinking.
- To recover the cruising range value display add fuel to at least the level needed for the fuel level warning indicators to stop blinking. The cruising range may still be displayed with

*a low fuel level, but it will not be accurate until enough fuel is added to stop the fuel level warning indicator from blinking.*

### **Clock**

To adjust the clock:

- Push the right meter button to select the clock.
- Push the right meter button and hold it until both the hour and minute displays blink.
- Push the right meter button and hold it until “12h” or “24h” is appeared on the display.
- Push the left meter button to select “12h” or “24h.”
- Push the right meter button to select the hour or minute digits.
- Push the left meter button to adjust the hour or minute digits.
- To finish the clock adjustment, push the left meter button when both the hour and minute digits blink.

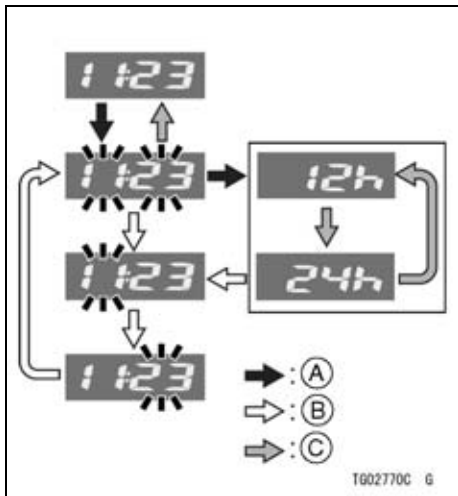

- A. Flow when pushing and holding right meter button  
 B. Flow when pushing right meter button  
 C. Flow when pushing left meter button

## NOTE

- When the battery is disconnected, the clock is reset to 1:00 ("24h" display: 13:00) and starts working again when the battery is connected.

## Unit Setting

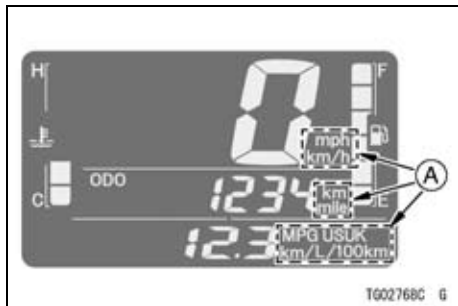

### A. Units

- Display the odometer in the multi-function display.

- Push the right meter button while pushing the left meter button to select the meter display units. The display units can be shifted in the following order.

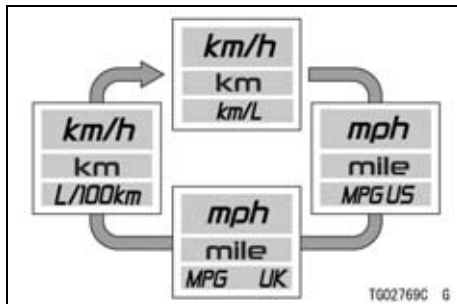

### ***Tachometer Display Setting***

The tachometer display can be select from three patterns.  
To select tachometer display:

- Push the left and right meter buttons and hold them until the tachometer gauge sweeps.
- Push the right meter button to select the tachometer display pattern.

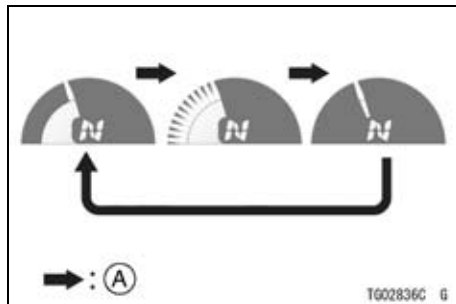

#### **A. Flow when pushing right meter button**

- To finish the selecting, push the left and right meter buttons and hold them a few seconds.

## NOTE

- *When the tachometer gauge sweeps, push the left meter button and hold it to display the shift-up indicator setting mode.*

### **Shift-up Indicator Setting**

The shift-up engine speed can be adjusted between 5 000 r/min (rpm) and 10 000 r/min (rpm) while the motorcycle is at a stop.

To set the setting:

- Push the left and right meter buttons and hold them until the tachometer gauge sweeps.
- Push the left meter button and hold it to display the shift-up indicator setting mode.



**A. Shift-up Indicator (Tachometer Gauge)**

- Push the right meter button to adjust the shift-up engine speed.

## NOTE

- *When pushing the right meter button, the shift-up engine speed increases in 500 r/min (rpm) increments up to 10 000 r/min (rpm).*
- *If the shift-up engine speed increases up to 10 000 r/min (rpm), the shift-up indicator is off, and then*

*the shift-up engine speed returns to 5 000 r/min (rpm) and begin increasing.*

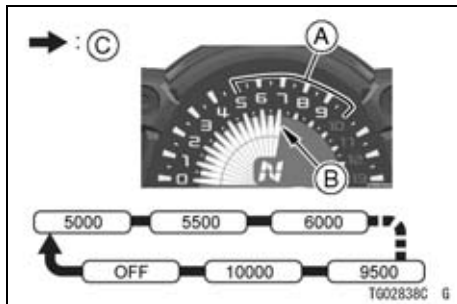

- A. Adjustable Range
- B. Current Setting
- C. Flow when pushing right meter button

- To finish the adjustment, push the left and right meter buttons and hold them a few seconds.

## **⚠ WARNING**

Failing to properly observe the road ahead increases the chance of an accident. Do not concentrate on the shift-up indicator by taking your eyes off the road, observe using peripheral vision. When shifting down to a lower gear, do not shift at such a high speed that the engine r/min (rpm) jumps excessively. Not only can this cause engine damage, but the rear wheel may skid and cause an accident. Downshifting should be done below 5 000 r/min (rpm) for each gear.

**NOTICE**

Engine speed should not be allowed to enter the red zone; operation in the red zone will overstress the engine and may cause serious engine damage.



A. Economical Riding Indicator

**Features*****Economical Riding Indicator***

When riding the motorcycle efficiently, the economical riding indicator appears on the multifunction meter to indicate favorable fuel consumption. Monitoring the economical riding indicator can help the rider maximize fuel efficiency.

**⚠ WARNING**

Failing to properly observe the road ahead increases the chance of an accident resulting in severe injury or death. Do not concentrate on the economical riding indicator by taking your eyes off the road; observe using peripheral vision.

***Fuel Gauge***

The fuel in the fuel tank is shown by the number of segments displayed.

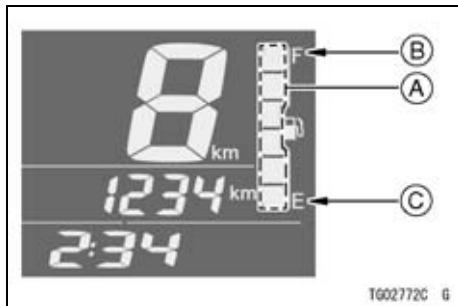

- A. Segments
- B. F (Full)
- C. E (Empty)

### NOTE

- When the fuel tank is full, all the segments are displayed. As the fuel

level in the tank goes down, the segments disappear one by one from F (full) to E (empty).

- When the fuel level warning indicator and bottom segment blink, refer to the “When Warning Indicators Go On or Blink” of Indicators in this chapter.

### Gear Position Indicator

This display shows the corresponding gear position when the transmission is shifted. As the transmission is shifted, the corresponding gear position (1st ~ 6th) is shown in this display. When the transmission is in neutral, “N” is displayed, and the neutral indicator goes on.

## 64 GENERAL INFORMATION

1	When the transmission is in 1st gear, "1" is displayed.
2	When the transmission is in 2nd gear, "2" is displayed.
3	When the transmission is in 3rd gear, "3" is displayed.
4	When the transmission is in 4th gear, "4" is displayed.
5	When the transmission is in 5th gear, "5" is displayed.
6	When the transmission is in 6th gear, "6" is displayed.

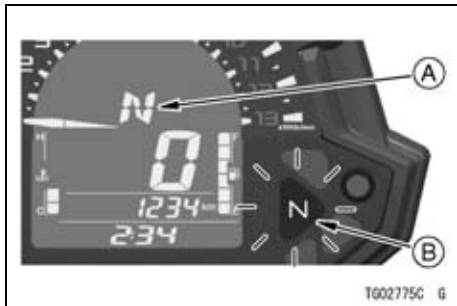

- A. Gear Position Indicator
- B. Neutral Indicator (Green)

### NOTE

- If the gear position display in the multifunction meter blinks "-", the transmission is not properly shifted to 1st. Be sure to shift the transmission.

## Keys

You will need the key number or spare key to have a duplicate made.

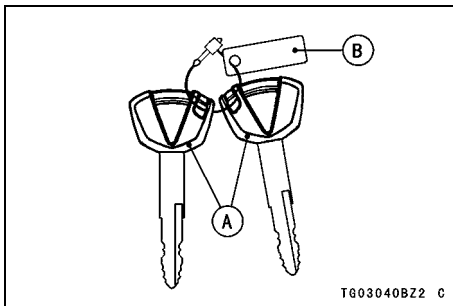

TG03040BZ2 C

- A. Ignition Key
- B. Key Number Tag

If you lose all keys and the key number, you will need to replace the ignition switch and all other locks operated by that key.

Contact your Kawasaki dealer to purchase additional spare keys.

## Ignition Switch/Steering Lock

This is a four-position, key-operated switch.

The key can be removed when it is in the "OFF," "LOCK" or  position.

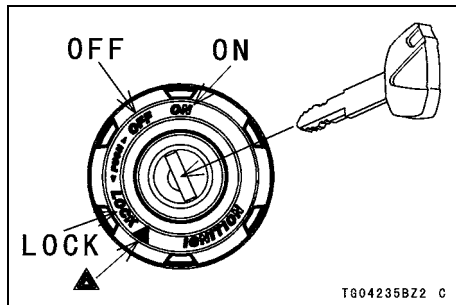

TG04235BZ2 C

## 66 GENERAL INFORMATION

<b>ON</b>	<ul style="list-style-type: none"><li>● Engine can be started.</li><li>● All electrical equipment can be used.</li><li>● Key cannot be removed.</li></ul>
<b>OFF</b>	<ul style="list-style-type: none"><li>● Engine off.</li><li>● Electrical equipment is off.</li><li>● Key can be removed.</li></ul>
<b>LOCK</b>	<ul style="list-style-type: none"><li>● Steering locked.</li><li>● Engine off.</li><li>● Electrical equipment is off.</li><li>● Key can be removed.</li></ul>
	<ul style="list-style-type: none"><li>● Steering locked.</li><li>● Engine off.</li><li>● Hazard lights can be used.</li><li>● Key can be removed.</li></ul>

For Locking:

1. Turn the handlebars fully to the left.
2. Push the key down in the “OFF” position and turn it to “LOCK” or  .



TG04227B S

### **WARNING**

**Turning the ignition switch to the “OFF” position while riding the motorcycle shuts down the entire electrical system (headlight, brake light, turn signal light, etc) and the engine will stop, which could cause an accident resulting in severe injury or death. Never operate the ignition switch while riding the motorcycle; only operate it when the motorcycle is at a standstill.**

**NOTE**

- *The tail, city and license plate lights are on whenever the ignition key is in the “ON” position. The headlight goes on when the starter button is released after starting the engine.*
- *Do not leave the ignition switch at the “ON” position for an extended time with the engine stopped, or the battery may become totally discharged.*
- *Do not leave the hazard lights switched on for a long time without the engine running or the battery will become discharged.*

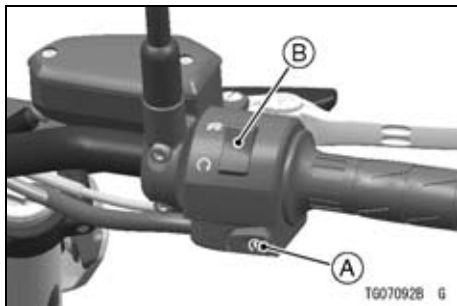
**Right Handlebar Switches**

- A. Starter Button**
- B. Engine Stop Switch**

**Starter Button** ⓘ

Refer to the Starting the Engine section in the HOW TO RIDE THE MOTORCYCLE chapter for starting instructions.

## Engine Stop Switch

To stop the engine in an emergency, move the engine stop switch to the  position.

Ordinarily, the engine stop switch must be in the  position for the motorcycle to operate.

### NOTE

- Ordinarily, the ignition switch should be used to stop the engine.
- Although the engine stop switch stops the engine, it does not turn off all the electrical circuits and eventually the battery will be discharged.

## Left Handlebar Switches

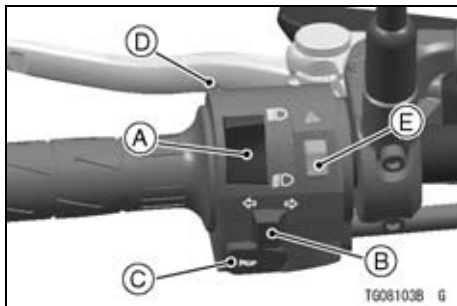

- A. Dimmer Switch
- B. Turn Signal Switch
- C. Horn Button
- D. Passing Button
- E. Hazard Switch

### Dimmer Switch

High or low beam can be selected with the dimmer switch.



High beam...  (High beam indicator: see Meter Instruments section)

Low beam...  (Single light goes on)

### NOTE

- Do not allow anything to cover the headlight lens when the headlight is on. If covered, heat can build up in the headlight lens causing lens discoloration or melting, as well as damage to the item covering the lens.

### Turn Signal Switch

When the turn signal switch is turned to the left (  ) or right (  ) the corresponding turn signal lights and turn signal indicator blinks. To cancel the turn signal, push the switch in.

### Horn Button

When the horn button is pushed, the horn sounds.

### Passing Button <sup>PASS</sup>

The high beam turns on only while the passing button is pushed.

### Hazard Switch

Push in the hazard switch with the ignition switch in the “ON” position or the  position. All the turn signal lights and turn signal indicators will blink.

### NOTE

- Be careful not to use the hazard lights for an extended period of time, otherwise the battery may become totally discharged.

## Brake Lever Adjuster

While pushing the brake lever forward, rotate the adjuster and choose a suitable lever position from the five positions.

## 70 GENERAL INFORMATION

### [Brake Lever Adjustment]

Adjuster Position	1	2	3	4	5
Lever Position	Far ←	—	→	Near	

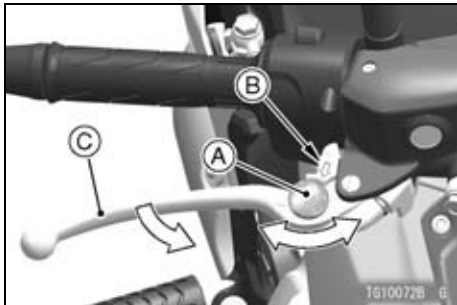

- A. Adjuster
- B. Mark
- C. Brake Lever

suitable lever position from the five positions.

### [Clutch Lever Adjustment]

Adjuster Position	1	2	3	4	5
Lever Position	Far ←	—	→	Near	

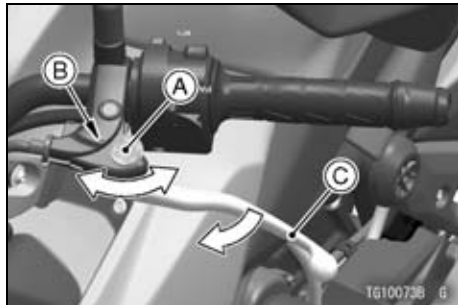

- A. Adjuster
- B. Mark
- C. Clutch Lever

## Clutch Lever Adjuster

While pushing the clutch lever forward, rotate the adjuster and choose a

## Fuel

### **WARNING**

Gasoline is extremely flammable and can be explosive under certain conditions, creating the potential for serious burns. Turn the ignition switch off.

Do not smoke.

Make sure the area is well ventilated and free from any source of flame or sparks; this includes any appliance with a pilot light.

---

### Fuel Requirements

---

Use clean, fresh unleaded gasoline with the following conditions.

- Antiknock Index of 87 or more
- Up to 10% of ethanol contained

### **NOTICE**

Use only unleaded gasoline. Never use leaded gasoline. Leaded gasoline significantly reduces the capability of the catalytic converter in the exhaust system.

### **NOTICE**

Use minimum of 87 octane gasoline only to prevent severe engine damage.

**NOTICE**

If engine “knocking” or “pinging” occurs, use a different brand of gasoline of a higher octane rating. If this condition is allowed to continue it can lead to severe engine damage. Gasoline quality is important. Fuels of low quality or not meeting standard industry specifications may result in unsatisfactory performance. Operating problems that result from the use of poor quality or nonrecommended fuel may not be covered under your warranty.

**NOTICE**

Avoid using blends of unleaded gasoline and methanol (wood alcohol) whenever possible, and never use “gasohol” containing more than 5% methanol. Fuel system damage and performance problems may result.

**NOTE**

- *Other oxygenates approved for use in unleaded gasoline include TAME (up to 16.7%) and ETBE (up to 17.2%). Fuel containing these oxygenates can also be used in your Kawasaki.*

## **NOTICE**

**Never use gasoline with an octane rating lower than the minimum specified by Kawasaki. Never use “gasohol” with more than 10% ethanol, or more than 5% methanol.**

**Gasoline containing methanol must also be blended with cosolvents and corrosion inhibitors.**

**Certain ingredients of gasoline may cause paint fading or damage. Be extra careful not to spill gasoline or gasoline oxygenate blends during refueling.**

**When not operating your Kawasaki for 30 to 60 days, mix a fuel stabilizer (such as STA-BIL) with the gasoline in the fuel tank. Fuel stabilizer additives inhibit oxidation of the fuel which minimizes gummy deposits.**

### ***Fuel Type and Octane Rating***

Use clean, fresh unleaded gasoline.

The Antiknock Index is posted on service station pumps. The octane rating of a gasoline is a measure of its resistance to detonation or “knocking.” The Antiknock Index is an average of the Research Octane Number (RON) and the Motor Octane Number (MON) as shown in the table.

Fuel Type	Unleaded Gasoline
Ethanol Content	E10 or less
Antiknock Index	87 or more

## ***NOTICE***

**Do not use any fuel that contains more ethanol or other oxygenates than specified for E10 fuel\* in this vehicle. Damage to the engine and fuel system, or engine starting and/or performance problems may result from the use of improper fuel.**

\*E10 means fuel containing up to 10% ethanol.

---

## **Filling the Tank**

---

Avoid filling the tank in the rain or where heavy dust is blowing so that the fuel does not get contaminated.

## **WARNING**

**Gasoline is extremely flammable and can be explosive under certain conditions, creating the potential for serious burns. Turn the ignition switch off. Do not smoke.**

**Make sure the area is well ventilated and free from any source of flame or sparks; this includes any appliance with a pilot light. Never fill the tank completely to the top.**

**If the tank is filled completely to the top, heat may cause the fuel to expand and overflow through the vents in the tank cap.**

**After refueling, make sure the tank cap is closed securely. If gasoline is spilled on the fuel tank, wipe it off immediately.**

**NOTICE**

**California model only: Never fill the tank so the fuel level rises into the filler neck. If the tank is overfilled, heat may cause the fuel to expand and flow into the Evaporative Emission Control System resulting in hard starting, engine hesitation and non-compliance with the emission regulation.**

- Lift the key hole cover.
- Insert the ignition key into the fuel tank cap.
- Turn the key clockwise while pushing down the fuel tank cap.

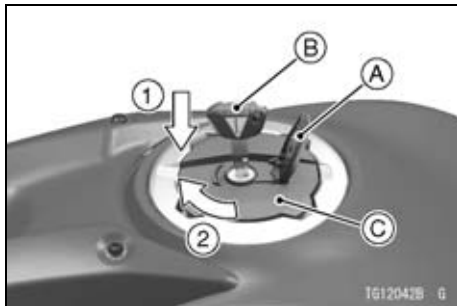

- A. Key Hole Cover
- B. Ignition Key
- C. Fuel Tank Cap

- Open the fuel tank cap.
- Add fuel.

## 76 GENERAL INFORMATION

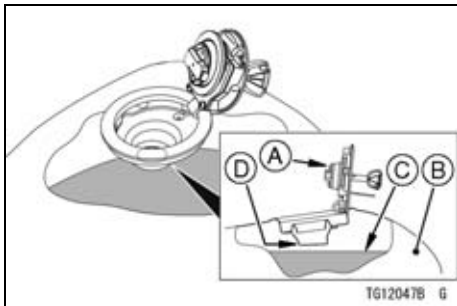

- A. Tank Cap
- B. Fuel Tank
- C. Top Level
- D. Bottom of Filler Neck (Maximum Fuel Level)

### NOTE

- *Do not exceed the maximum fuel level as shown.*
- Push the fuel tank cap down into place with the key inserted.

- The key can be removed by turning counterclockwise to the original position.
- Close the key hole cover.

### NOTICE

**Never fill the tank completely to the top.  
If the tank is filled completely to the top, heat may cause the fuel to expand and overflow through the vents in the tank cap.  
After refueling, make sure the tank cap is closed securely.  
If gasoline is spilled on the fuel tank, wipe it off immediately.**

### NOTE

- *The fuel tank cap cannot be closed without the key inserted, and the key*

*cannot be removed unless the cap is locked properly.*

- *Do not push on the key to close the cap, or the cap cannot be locked.*

## Side Stand

Always kick the stand fully up before moving the motorcycle. The engine will stop automatically if the motorcycle is in gear and the clutch is released with the side stand down.

### NOTE

- *When using the side stand, turn the handlebars to the left.*
- *Make sure the side stand is down securely before leaving the motorcycle.*

- *Do not sit on the motorcycle while it is on its side stand.*

## Seats

The seats can be removed by in order of the passenger's seat then the rider's seat.

### ***Passenger's Seat Removal***

- Insert the ignition key into the seat lock.
- Lift the front part of the passenger's seat upward while turning the key clockwise.
- Remove the passenger's seat forward.
- Remove the ignition key.

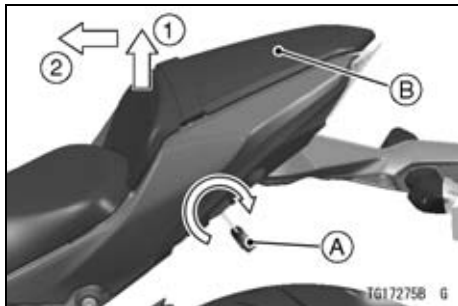

- A. Ignition Key
- B. Passenger's Seat

### ***Passenger's Seat Installation***

- Insert the hook at the rear of the passenger's seat into the slot of the frame.
- Insert the latch plate at the front of the passenger's seat into the latch hole of the frame.
- Push down the front part of the passenger's seat until the lock clicks.



- A. Hook
- B. Slot
- C. Latch Plate
- D. Latch Hole

- Pull up the front and rear ends of the passenger's seat to make sure they are securely locked.

### ***Rider's Seat Removal***

- Remove the passenger's seat (see Passenger's Seat Removal).

- Lift the rear part of the rider's seat upward, and remove the rider's seat rearward.

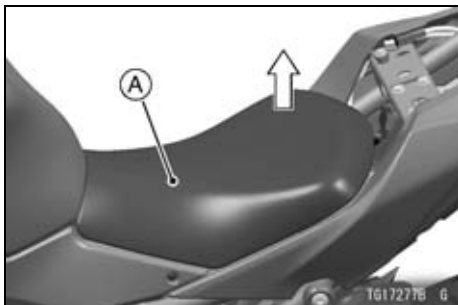

A. Rider's Seat

### ***Rider's Seat Installation***

- Insert the hook at the front of the rider's seat into the slot of the bracket.
- Fit the tab at the rear of the rider's seat on the guide of the frame.

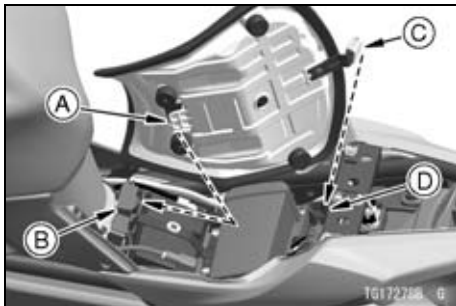

- A. Hook
- B. Slot
- C. Tab
- D. Guide

## **Tie Hooks**

When tying up light loads to the seat, use the tie hooks located in rear of the rear footpegs.

## 80 GENERAL INFORMATION



A. Tie Hooks

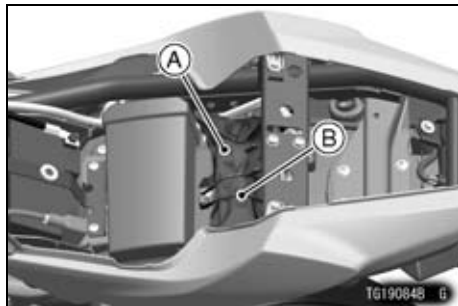

A. Tool Kit  
B. Band

### Tool Kit

The tool kit is located under the rider's seat.

Keep the tool kit in the original place. Hold the tool kit with the band securely.

### Rear View Mirrors

#### *Rear View Mirror Adjustment*

- Adjust the rear view mirror by slightly moving only the mirror portion of the assembly.
- If the rear visibility cannot be assured by moving the mirror, slide the rubber

boot up, and loosen the locknut and turn the stay by hand.

### NOTE

- *The locknut has left hand threads.*
- Tighten the locknut securely.

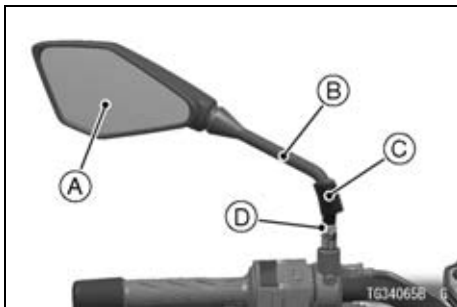

- A. Rear View Mirror
- B. Stay
- C. Rubber Boot
- D. Locknut

## Event Data Recorder

In common with many other vehicle manufacturers, Kawasaki has equipped this motorcycle with an event data recorder (EDR). The purpose of this device is to record data that assists with understanding of how some of the vehicle's systems were performing during a short period of time immediately before and during an accident or similar event involving minor damage. Due to accident variables, all vehicle performance data may not be stored on the EDR.

### NOTE

- *During normal riding, data is recorded but not saved unless the vehicle is involved in an accident event.*
- *At no time other than in the event of an accident or similar event involving*

## 82 GENERAL INFORMATION

*minor damage is it possible for EDR data to be stored for retrieval.*

- *Depending on the type of accident event, it is possible that the EDR may not record some or all of the data, or it may not record if the EDR is damaged.*
- *This device does not collect or store personal data or information (e.g. name, gender, age).*

The EDR in this vehicle is designed to record only data that is relevant to the vehicle's running condition at the time of an accident like, but not limited to,

vehicle speed, engine crankshaft rotational speed and throttle opening, etc.

This data can help provide a better understanding for both the rider and the manufacturer of how the vehicle was performing at the time of an accident or near accident-like situation.

To access information on an EDR, special equipment and access to the EDR is required. Kawasaki will not share EDR information without obtaining your consent, unless required by government authorities, or acting pursuant to lawful authority.

# HOW TO RIDE THE MOTORCYCLE

## Break-In

The first 1 600 km (1 000 mile) that the motorcycle is ridden is designated as the break-in period. If the motorcycle is not used carefully during this period, you may very well end up with a “broken down” instead of a “broken in” motorcycle after a few thousand kilometers.

The following rules should be observed during the break-in period.

- The table shows maximum recommended engine speed during the break-in period.

Distance traveled	Maximum engine speed
0 ~ 800 km (0 ~ 500 mile)	4 000 r/min (rpm)
800 ~ 1 600 km (500 ~ 1 000 mile)	6 000 r/min (rpm)

## NOTE

- *When operating on public roadways, keep maximum speed under traffic law limits.*
- Do not start moving or race the engine immediately after starting it, even if the engine is already warm. Run the engine for two or three minutes at idle speed to give the oil a chance to work up into all the engine parts.

## 84 HOW TO RIDE THE MOTORCYCLE

- Do not race the engine while the transmission is in neutral.

### **⚠ WARNING**

**New tires are slippery and may cause loss of control and injury. A break-in period of 160 km (100 miles) is necessary to establish normal tire traction. During break-in, avoid sudden and maximum braking and acceleration, and hard cornering.**

In addition to the above, at 1 000 km (600 mile) it is extremely important that the owner has the initial maintenance service performed by an authorized Kawasaki dealer.

## Starting the Engine

- Check that the engine stop switch is in the  position.

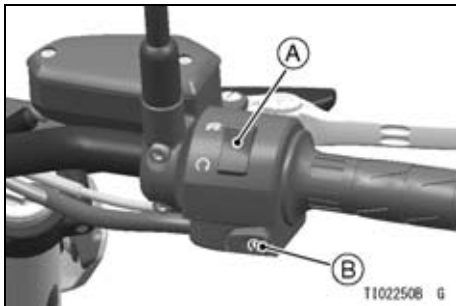

- A. Engine Stop Switch**
- B. Starter Button**

- Turn the ignition key to “ON” position.
- Make sure the transmission is in neutral.

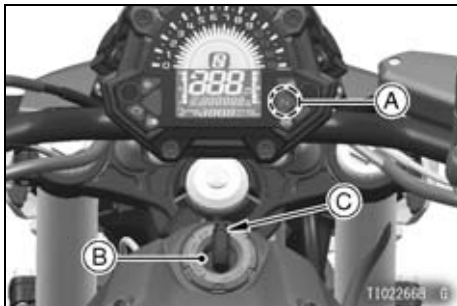

- A. Neutral Indicator (Green)
- B. Ignition Switch
- C. ON Position

### NOTE

- While the engine is cold, the fast idle system automatically raises the engine idling speed. At this time, the engine warning indicator (  ) may go on if you operate the throttle grip unnecessarily.

- The motorcycle is equipped with a vehicle-down sensor which causes the engine to stop automatically if the motorcycle falls down. After righting the motorcycle, first turn the ignition key to “OFF” and then back to “ON” before starting the engine.
- Without holding the throttle grip, push the starter button to start the engine.

### NOTICE

**Do not operate the starter continuously for more than 5 seconds, or the starter will overheat and the battery power will drop temporarily. Wait 15 seconds between each operation of the starter to let it cool and the battery power recover.**

**NOTE**

- *The motorcycle is equipped with a starter lockout switch. This switch is designed so that the engine does not start if the transmission is in gear and the side stand is down. However, the engine can be started if the clutch lever is pulled and the side stand is fully up.*

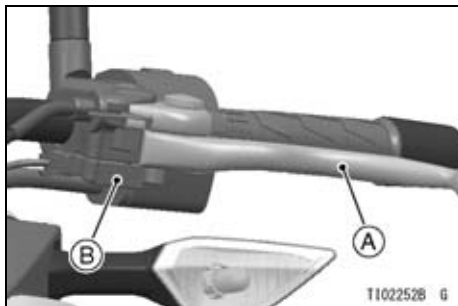

- A. Clutch Lever
- B. Starter Lockout Switch

**NOTICE**

**Do not let the engine idle longer than 5 minutes, or engine overheating and damage may occur.**

**Moving Off**

- Check that the side stand is up.
- Pull in the clutch lever.
- Shift into 1st gear.
- Open the throttle a little, and start to let out the clutch lever very slowly.
- As the clutch starts to engage, open the throttle a little more, giving the engine just enough fuel to keep it from stalling.

**NOTE**

- *The motorcycle is equipped with a side stand switch. This switch is designed so that the engine does not*

*start if the transmission is in gear and the side stand is down.*

## Shifting Gears

- Close the throttle while pulling in the clutch lever.
- Shift into the next higher or lower gear.

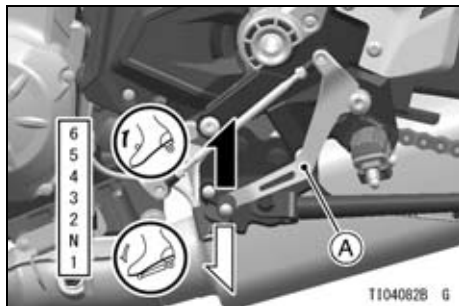

A. Shift Pedal

- For smooth riding, each gear position should cover the proper rate of speed shown in the table.

### **⚠ WARNING**

**Downshifting to a lower gear at high speed causes engine rpm to increase excessively, potentially damaging the engine and it may also cause the rear wheel to skid and cause an accident. Downshifting should be done below the vehicle speeds for each gear shown in the table.**

## Vehicle speed when shifting

Shifting up	km/h (mph)
1st → 2nd	15 (9)
2nd → 3rd	25 (15)
3rd → 4th	35 (21)
4th → 5th	45 (27)
5th → 6th	55 (34)

Shifting down	km/h (mph)
6th → 5th	30 (19)
5th → 4th	25 (15)
4th → 3rd	20 (12)
3rd → 2nd	15 (9)
2nd → 1st	15 (9)

**NOTE**

- *The transmission is equipped with a positive neutral finder. When the motorcycle is standing still, the transmission cannot be shifted past neutral from 1st gear. To use the positive neutral finder, shift down to 1st gear, then lift up on the shift pedal while standing still. The transmission will shift only into neutral.*

**Braking**

- Close the throttle completely, leaving the clutch engaged (except when shifting gears) so that the engine will help slow down the motorcycle.
- Shift down one gear at a time so that you are in 1st gear when you come to a complete stop.
- When stopping, always apply both brakes at the same time. Normally

the front brake should be applied a little more than the rear. Shift down or fully disengage the clutch as necessary to keep the engine from stalling.

- Never lock the brakes, or it will cause the tires to skid. When turning a corner, it is better not to brake at all. Reduce your speed before you get into the corner.
- For emergency braking, disregard downshifting, and concentrate on applying the brakes as hard as possible without skidding.
- Even in motorcycles equipped with ABS, braking during cornering may cause wheel slip. When turning a corner, it is better to limit braking to

the light application of both brakes or not to brake at all. Reduce your speed before you get into the corner.

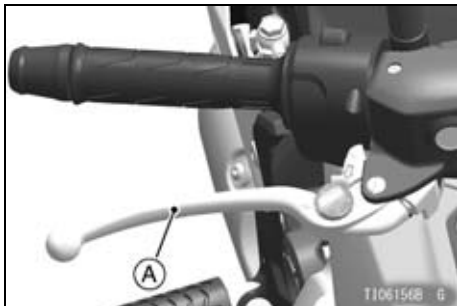

**A. Front Brake Lever**



A. Rear Brake Pedal

## Anti-lock Brake System (ABS)

(only on ABS model)

ABS is designed to help prevent the wheels from locking up when the brakes are applied hard while running straight. The ABS automatically regulates brake force. Intermittently gaining gripping force and braking force helps

prevent wheel lock-up and allows stable steering control while stopping.

Brake control function is identical to that of a conventional motorcycle. The brake lever is used for the front brake and the brake pedal for the rear brake.

Although the ABS provides stability while stopping by preventing wheel lock-up, remember the following characteristics:

- To apply the brake effectively, use the front brake lever and rear brake pedal simultaneously in the same manner as conventional motorcycle brake system.
- ABS cannot compensate for adverse road conditions, misjudgment or improper application of brakes. You must take the same care as with motorcycles not equipped with ABS.
- ABS is not designed to shorten the braking distance. On loose, uneven or downhill surfaces, the stopping

distance of a motorcycle with ABS may be longer than that of an equivalent motorcycle without ABS. Use special caution in such areas.

- ABS will help prevent wheel lock-up when braking in a straight line, but it cannot control wheel slip which may be caused by braking during cornering. When turning a corner, it is better to limit braking to the light application of both brakes or not to brake at all. Reduce your speed before you get into the corner.
- Same as conventional brake system, an excessive sudden braking may cause wheel lock up that makes it harder to control a motorcycle.
- During braking, ABS will not prevent the rear wheel lifting.

## **WARNING**

**ABS cannot protect the rider from all possible hazards and is not a substitute for safe riding practices. Be aware of how the ABS system operates and its limitations. It is the rider's responsibility to ride at appropriate speeds and manner for weather, road surface and traffic conditions.**

- The computers integrated in the ABS compare vehicle speed with wheel speed. Since non-recommended tires can affect wheel speed, they may confuse the computers, which can extend braking distance.

## WARNING

Use of non-recommended tires may cause malfunctioning of ABS and can lead to extended braking distance. The rider could have an accident as a result. Always use recommended standard tires for this motorcycle.

## NOTE

- *When the ABS is functioning, you may feel a pulsing in the brake lever or pedal. This is normal. You need not suspend applying brakes.*
- *ABS does not function at speeds of approx. 5 km/h (3.1 mph) or below.*
- *ABS does not function if the battery is discharged. When riding with an insufficiently charged battery, ABS may not function. Keep the battery in good condition according to*

*the “Battery Maintenance” section in the MAINTENANCE AND ADJUSTMENT chapter.*

## Stopping the Engine

- Close the throttle completely.
- Shift the transmission into neutral.
- Turn the ignition key to “OFF.”
- Support the motorcycle on a firm, level surface with the side stand.
- Lock the steering.

## Stopping the Motorcycle in an Emergency

Your Kawasaki Motorcycle has been designed and manufactured to provide you optimum safety and convenience. However, in order to fully benefit from Kawasaki’s safety engineering and craftsmanship, it is essential that

you, the owner and operator, properly maintain your motorcycle and become thoroughly familiar with its operation. Improper maintenance can create a dangerous situation known as throttle failure. Two of the most common causes of throttle failure are:

1. An improperly serviced or clogged air cleaner may allow dirt and dust to enter the throttle body and stick the throttle open.
2. During removal of the air cleaner, dirt is allowed to enter and jam the fuel injection system.

In an emergency situation such as throttle failure, your vehicle may be stopped by applying the brakes and disengaging the clutch. Once this stopping procedure is initiated, the engine stop switch may be used to stop

the engine. If the engine stop switch is used, turn off the ignition switch after stopping the motorcycle.

## Parking

### **WARNING**

**Operating or parking the vehicle near flammable materials can cause a fire, and can result in property damage or severe personal injury.**

**Do not idle or park your vehicle in an area where tall or dry vegetation, or other flammable materials could come into contact with the muffler or exhaust pipe.**

**⚠ WARNING**

**The engine and exhaust system get extremely hot during normal operation and can cause serious burns.**

**Never touch a hot engine, exhaust pipe, or muffler during operation or after stopping the engine.**

- Shift the transmission into neutral and turn the ignition key to “OFF.”
- Support the motorcycle on a firm, level surface with the side stand.

***NOTICE***

**Do not park on a soft or steeply inclined surface, or the motorcycle may fall over.**

- If parking inside a garage or other structure, be sure it is well ventilated

and the motorcycle is not close to any source of flame or sparks; this includes any appliance with a pilot light.

**⚠ WARNING**

**Gasoline is extremely flammable and can be explosive under certain conditions, creating the potential for serious burns. Turn the ignition switch off. Do not smoke. Make sure the area is well ventilated and free from any source of flame or sparks; this includes any appliance with a pilot light.**

- Lock the steering to help prevent theft.

**NOTE**

- *When stopping near traffic at night, you can leave the turn signal lights*

*blinking for greater visibility by turning the ignition key to the  position and push in the hazard switch.*

## MAINTENANCE AND ADJUSTMENT

The maintenance and adjustments outlined in this chapter must be carried out in accordance with the Daily Checks and Periodic Maintenance to keep the motorcycle in good running condition and to reduce air pollution. **The initial maintenance is vitally important and must not be neglected.**

### WARNING

**Failure to perform these checks or to correct a problem before operation may result in serious damage or an accident. Always perform daily checks before operation.**

With a basic knowledge of mechanics and the proper use of tools, you should be able to carry out many of the maintenance items described in this chapter. If you lack proper experience or doubt your ability, all adjustments, maintenance, and repair work should be completed by a qualified technician.

Please note that Kawasaki cannot assume any responsibility for damage resulting from incorrect or improper adjustment made by the owner.

 **DANGER**

Exhaust gas contains carbon monoxide, a colorless, odorless poisonous gas. Inhaling carbon monoxide can cause serious brain injury or death. **DO NOT** run the engine in enclosed areas. Operate only in a well-ventilated area.

 **WARNING**

The cooling fan spins at high speed and can cause serious injuries. Keep your hands and clothing away from the cooling fan blades at all times.

**NOTE**

- *If a torque wrench is not available, the maintenance items which require a specific torque value should be serviced by an authorized Kawasaki dealer.*

## Daily Checks

Check the following items each day before you ride. The time required is minimal, and habitual performance of these checks will help ensure you a safe, reliable ride.

If any irregularities are found during these checks, refer to the MAINTENANCE AND ADJUSTMENT chapter or see your dealer for the action required to return the motorcycle to a safe operating condition.

Operation	See Page
<b>Fuel</b> Adequate supply in tank, no leaks	–
<b>Engine oil</b> Oil level between level lines	106
<b>Tires</b> Air pressure (when cold), install the air valve cap Tire wear	132 132
<b>Drive chain</b> Slack Lubricate if dry	120 119

Operation	See Page
<b>Bolts, nuts and fasteners</b> Check for loose and/or missing bolts, nuts and fasteners	—
<b>Steering</b> Action smooth but not loose from lock to lock No binding of control cables	— —
<b>Brakes</b> Brake pad wear Brake fluid level No brake fluid leakage	125 124 —
<b>Throttle</b> Throttle grip free play	114
<b>Clutch</b> Clutch lever free play Clutch lever operates smoothly	118 —
<b>Coolant</b> No coolant leakage	—

## 100 MAINTENANCE AND ADJUSTMENT

Operation	See Page
Coolant level between level lines (when engine is cold)	110
<b>Electrical equipment</b> All lights (head, city, tail/brake, turn signal, license plate, warning/indicator) and horn work	—
<b>Engine stop switch</b> Stops engine	—
<b>Side stand</b> Return to its fully up position by spring tension Return spring not weak or not damaged	— —
<b>Rear view mirrors</b> Rear view sight	—

## Periodic Maintenance

- \*A: Service at number of years shown or indicated odometer reading intervals, whichever comes first.
- \*B: For higher odometer readings, repeat at the frequency interval established here.
- \*C: Service more frequently when operating in severe conditions: dusty, wet, muddy, high speed, or frequent starting/stopping.
- \*D: California model only
- : Emission Related Item

: Inspection

: Dealer Inspection



: Change or Replace

: Dealer Change or Replace

: Lubrication

: Dealer Lubrication

## 102 MAINTENANCE AND ADJUSTMENT

Items		year (*A)	Odometer Reading (*B) × 1 000 km (× 1 000 mile)					See Page
			1 (0.6)	6 (3.8)	12 (7.6)	18 (11.4)	24 (15.2)	
○	Air cleaner element (*C)							113
○	Idle speed		Q		Q		Q	117
○	Throttle control system (play, smooth return, no drag)	Q:1	Q		Q		Q	114
○	Engine vacuum synchronization				Q		Q	–
	Fuel system	Q:1	Q		Q		Q	–
	Fuel filter							–
	Fuel hose	 :5						–
○	Evaporative emission control system (*D)		Q	Q	Q	Q	Q	–
	Coolant level		Q		Q		Q	110
	Cooling system	Q:1	Q		Q		Q	–

Items		year (*A)	Odometer Reading (*B) × 1 000 km (× 1 000 mile)					See Page
			1 (0.6)	6 (3.8)	12 (7.6)	18 (11.4)	24 (15.2)	
	Coolant, water hose and O-ring	:3	: every 36 000 km (22 500 mile)					–
<input type="radio"/>	Valve clearance							–
<input type="radio"/>	Air suction system							–
	Clutch operation (play, engagement, disengagement)							118
	Engine oil (*C) and oil filter	:1						107
	Tire air pressure	:1						132
	Wheel and tire	:1						132
	Wheel bearing damage	:1						–
	Drive chain lubrication condition (*C)		: every 600 km (400 mile)					119

## 104 MAINTENANCE AND ADJUSTMENT

Items	year (*A)	Odometer Reading (*B) × 1 000 km (× 1 000 mile)					See Page
		1 (0.6)	6 (3.8)	12 (7.6)	18 (11.4)	24 (15.2)	
Drive chain slack (*C)		Q: every 1 000 km (600 mile)					120
Drive chain wear (*C)				Q		Q	–
Drive chain guide wear				Q		Q	–
Brake system	Q:1	Q		Q		Q	–
Brake operation (effectiveness, play, no drag)	Q:1	Q		Q		Q	–
Brake fluid level	Q:1	Q		Q		Q	124
Brake fluid (front and rear)	G:2					G	–
Brake hose	G:4						–
Rubber parts of brake master cylinder and caliper	G:4	G: every 48 000 km (30 000 mile)					–

Items		year (*A)	Odometer Reading (*B) × 1 000 km (× 1 000 mile)					See Page
			1 (0.6)	6 (3.8)	12 (7.6)	18 (11.4)	24 (15.2)	
	Brake pad wear (*C)			Q	Q	Q	Q	125
	Brake light switch operation		Q	Q	Q	Q	Q	126
	Suspension system	Q:1			Q		Q	–
	Lubrication of rear suspension						↗	–
	Steering play	Q:1	Q		Q		Q	–
	Steering stem bearings	↗:2					↗	–
	Electrical system	Q:1			Q		Q	–
○	Spark plug				↻		↻	–
	Chassis parts	↗:1			↗		↗	–
	Condition of bolts, nuts and fasteners		Q		Q		Q	–

## Engine Oil

### *Oil Level Inspection*

- If the engine is cold, start the engine and run it for several minutes at idle speed.
- Stop the engine, then wait several minutes until the oil settles.

### **NOTICE**

**Racing the engine before the oil reaches every part can cause engine seizure.**

- Check the engine oil level through the oil level inspection window. With the motorcycle held level, the oil level should come up between the upper and lower level lines next to the oil level inspection window.

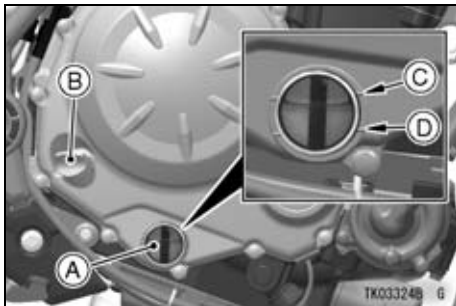

- A. Oil Level Inspection Window
- B. Oil Filler Cap
- C. Upper Level Line
- D. Lower Level Line

- If the oil level is too high, remove the excess oil through the oil filler opening using a syringe or some other suitable device.
- If the oil level is too low, add oil to reach the correct level. Use the same type and brand of oil that is already in the engine.

**Oil and/or Oil Filter Change**

- Warm up the engine thoroughly, and then stop it.
- Place an oil pan beneath the engine.
- Remove the engine oil drain bolt and gasket.

**⚠ WARNING**

**Engine oil is a toxic substance. Dispose of used oil properly. Contact your local authorities for approved disposal methods or possible recycling.**

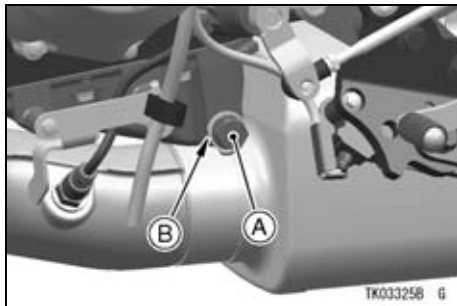

- A. Engine Oil Drain Bolt
- B. Gasket

- Let the oil completely drain with the motorcycle perpendicular to the ground.
- If the oil filter is to be replaced, remove the oil filter and replace it with a new one.

**NOTE**

- *If a torque wrench or required Kawasaki special tool is not available, this item should be serviced by an authorized Kawasaki dealer.*

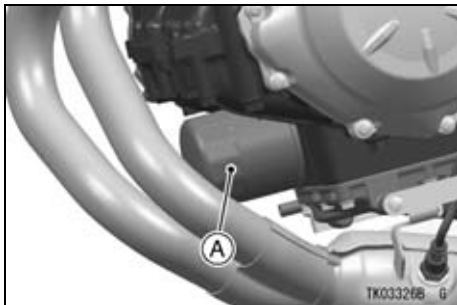

**A. Oil Filter**

- Apply a thin film of oil to the gasket and tighten the oil filter to the specified torque.

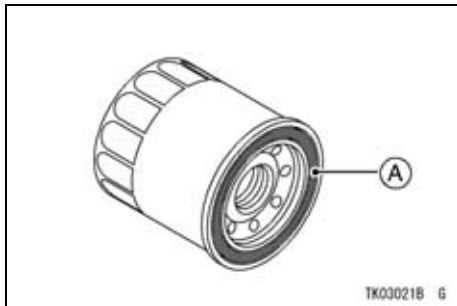

**A. Gasket**

- Install the drain bolt with a new gasket. Tighten it to the specified torque.

**NOTE**

- *Replace the gasket with a new one.*

**Tightening Torque**

Oil Filter:

17.5 N·m (1.78 kgf·m, 12.9 ft·lb)

Engine Oil Drain Bolt:

30 N·m (3.1 kgf·m, 22 ft·lb)

- Fill the engine up to the upper level line with a good quality engine oil specified in the table.

**Recommended Engine Oil**

Type:

Kawasaki Performance 4-Stroke  
Motorcycle Oil\*Kawasaki Performance 4-Stroke  
Semi-Synthetic Oil\*Kawasaki Performance 4-Stroke Full  
Synthetic Oil\*or other 4-stroke oils with API SG, SH,  
SJ, SL or SM with JASO MA, MA1 or  
MA2 rating

Viscosity:

SAE 10W-40

\*Kawasaki Performance Oils and Lubricants have been specifically engineered for your vehicle. Consistent use of these products meets or exceeds warranty and service requirements and can help to extend the life of your Kawasaki.

**NOTE**

- *Do not add any chemical additive to the oil. Oils fulfilling the above requirements are fully formulated and provide adequate lubrication for both the engine and the clutch.*

**Engine Oil Capacity**

1.6 L (1.7 US qt)

[when filter is not removed]

1.8 L (1.9 US qt)

[when filter is removed]

## 110 MAINTENANCE AND ADJUSTMENT

Although 10W-40 engine oil is the recommended oil for most conditions, the oil viscosity may need to be changed to accommodate atmospheric conditions in your riding area.

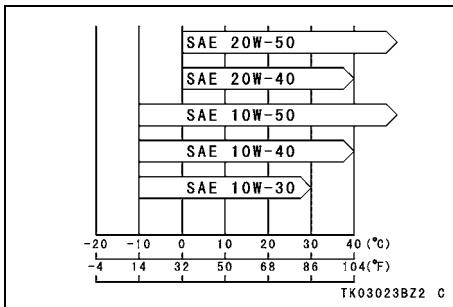

- Start the engine.
- Check the oil level and oil leakage.

## Coolant

### *Coolant Level Inspection*

- Position the motorcycle so that it is perpendicular to the ground.
- Check the coolant level through the coolant level gauge on the reserve tank located in right side cover. The coolant level should be between the F (Full) and L (Low) level lines.

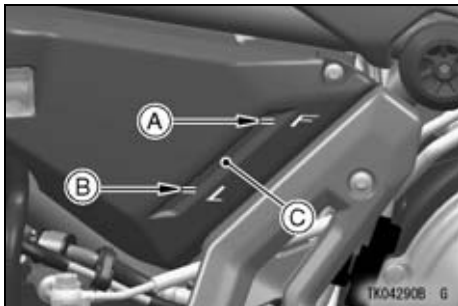

- A. F (Full) Level Line
- B. L (Low) Level Line
- C. Reserve Tank

### NOTE

- Check the level when the engine is cold (room or atmospheric temperature).
- If the amount of coolant is insufficient, add coolant into the reserve tank.

### Coolant Filling

- Remove the bolts and washer.
- Remove the right side cover.

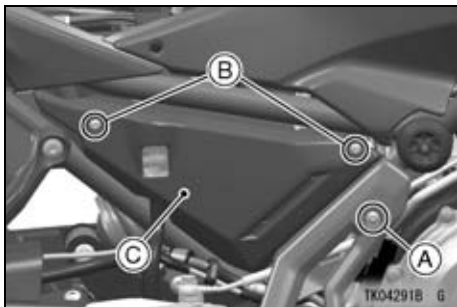

- A. Bolt and Washer
- B. Bolts
- C. Right Side Cover

- Remove the cap from the reserve tank and add coolant through the filler opening to the F (Full) level line.

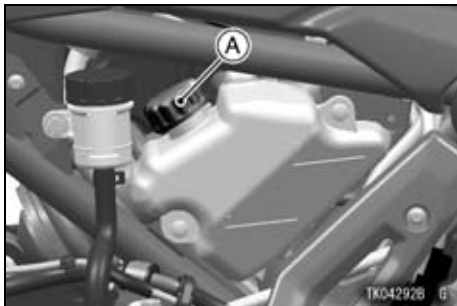

A. Reserve Tank Cap

### NOTE

- *In an emergency you can add water alone to the coolant reserve tank, however it must be returned to the correct mixture ratio by the addition of antifreeze concentrate as soon as possible.*

### NOTICE

If coolant must be added often, or the reserve tank completely runs dry, there is probably leakage in the system. Have the cooling system inspected by your authorized Kawasaki dealer.

- Install the right side cover, and tighten its bolts together with the washer.

### Coolant Change

Have the coolant changed by an authorized Kawasaki dealer.

### Coolant Requirement

#### **WARNING**

Coolant containing corrosion inhibitors for aluminum engines and radiators include harmful chemicals for human body. Drinking coolant can result in serious injury or death. Use coolant in accordance with the instructions of the manufacturer.

Use a permanent type of antifreeze (soft water and ethylene glycol plus corrosion and rust inhibitor chemicals for aluminum engines and radiators) in the cooling system. On the mixture ratio of coolant, choose the suitable one referring to the relation between freezing point and strength directed on the container.

#### **NOTICE**

If hard water is used in the system, it causes scale accumulation in the water passages, and considerably reduces the efficiency of the cooling system.

#### **NOTE**

- *A permanent type of antifreeze is installed in the cooling system when shipped. It is mixed at 50% and has the freezing point of  $-35^{\circ}\text{C}$  ( $-31^{\circ}\text{F}$ ).*

### **Air Cleaner**

This motorcycle's air cleaner element consists of a wet paper filter. Replacement of the air cleaner element should be done by an authorized Kawasaki dealer.

### *Oil Draining*

- Inspect the transparent drain hose located to the left of the engine to see if any oil has run down.

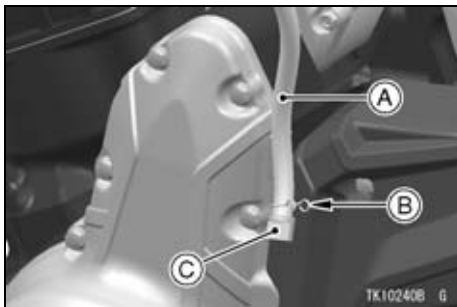

- A. Transparent Drain Hose
- B. Clamp
- C. Plug

- If there is any oil in the transparent drain hose, remove the clamp and plug from the lower end of the drain hose, and drain the oil.

## **⚠ WARNING**

**Oil on tires will make them slippery and can cause an accident and injury. Be sure to install the plug in the drain hose after draining.**

## **Throttle Control System**

### *Throttle Grip*

#### *Throttle Grip Free Play Inspection*

- Check that the throttle grip moves smoothly from full open to close, and the throttle closes quickly and completely by the return spring in all steering positions.
- If the throttle grip does not return properly, have the throttle control system checked by an authorized Kawasaki dealer.

- Check the throttle grip free play by turning back and forth.

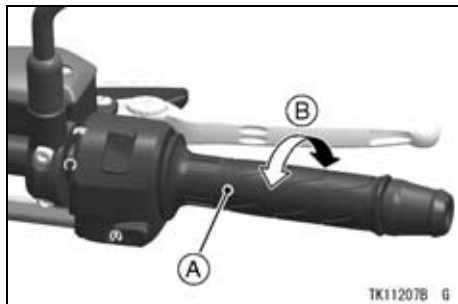

A. Throttle Grip  
B. Throttle Grip Free Play

### Throttle Grip Free Play

2 ~ 3 mm (0.08 ~ 0.12 in.)

- If there is improper play, adjust it.

### *Throttle Grip Free Play Adjustment*

- Loosen the locknuts at the upper end of the throttle cable and at the middle of the throttle cable.
- Turn both throttle cable adjuster to give the throttle grip plenty of play.
- Turn the decelerator cable adjuster until there is no play when the throttle grip is completely closed.
- Tighten the locknut.

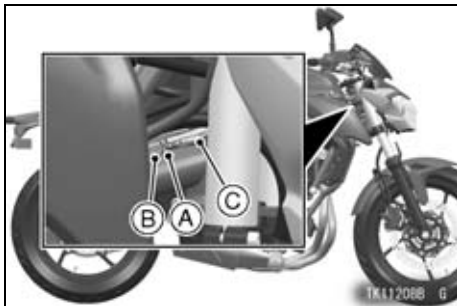

- A. Locknut
- B. Adjuster
- C. Decelerator Cable

- Turn the accelerator cable adjuster until of 2 ~ 3 mm (0.08 ~ 0.12 in.) of throttle grip play is obtained.
- Tighten the locknut.

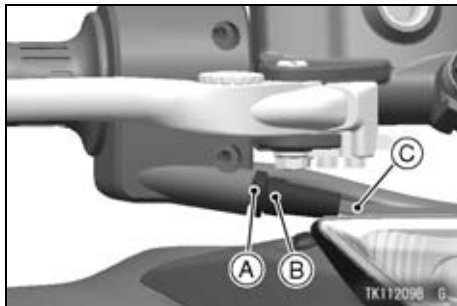

- A. Locknut
- B. Adjuster
- C. Accelerator Cable

- With the engine idling, turn the handlebars to each side. If handlebars movement changes the idle speed, the throttle cables may be improperly adjusted or incorrectly routed, or they may be damaged. Be sure to correct any of these conditions before idling.

## **⚠ WARNING**

Operation with improperly adjusted, incorrectly routed, or damaged cables could result in an unsafe riding condition. Be sure the control cables are adjusted and routed correctly, and are free from damage.

## Idle Speed

### *Idle Speed Adjustment*

- Start the engine, and warm it up thoroughly.
- Adjust the idle speed by turning the idle adjusting screw.

### **NOTE**

- *While the engine is cold, the fast idle system automatically raises the engine idling speed.*

### Idle Speed

1 250 ~ 1 350 r/min (rpm)



### A. Idle Adjusting Screw

- Open and close the throttle a few times to make sure that the idle speed does not change. Readjust if necessary.
- With the engine idling, turn the handlebars to each side. If handlebars movement changes the idle speed, the throttle cables may be improperly

## 118 MAINTENANCE AND ADJUSTMENT

adjusted or incorrectly routed, or they may be damaged. Be sure to correct any of these conditions before riding.

### **⚠ WARNING**

Operation with damaged cables could result in an unsafe riding condition. Replace damaged control cables before operation.

## Clutch

### *Clutch Operation Inspection*

- Check that the clutch lever operates properly and that the inner cable slides smoothly. If there is any irregularity, have the clutch cable checked by an authorized Kawasaki dealer.
- Check the clutch lever free play.

### Clutch Lever Free Play

2 ~ 3 mm (0.08 ~ 0.12 in.)

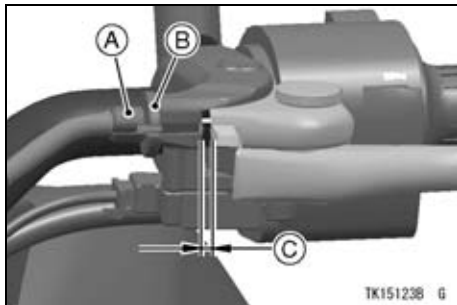

- A. Adjuster
- B. Locknut
- C. Clutch Lever Free Play

- If the free play is incorrect, adjust the clutch lever free play as follows.

**Clutch Lever Free Play Adjustment**

- Loosen the locknut, and turn the adjuster so that the clutch lever will have the specified free play.

**WARNING**

**Excess clutch lever free play could prevent clutch disengagement and cause a crash resulting in serious injury or death. When adjusting the clutch lever free play, be sure the upper end of the clutch outer cable is fully seated in its fitting so that it doesn't slip into place later and create excessive free play.**

- If it cannot be done, have the clutch cable adjusted by an authorized Kawasaki dealer.

**NOTE**

- *After the adjustment is made, start the engine and check that the clutch does not slip and that it releases properly.*

**Drive Chain****Drive Chain Lubrication**

Lubrication is necessary after riding through rain or on wet roads, or any time that the chain appears dry.

Use a lubricant for sealed chains to prevent deterioration of chain seals. If the chain is especially dirty, clean it using a cleaner for sealed chains following the instructions supplied by the chain cleaner manufacturer.

- Apply lubricant to the sides of the rollers so that it will penetrate to the rollers and bushings. Apply lubricant to the seals so that the seals will be

## 120 MAINTENANCE AND ADJUSTMENT

coated with lubricant. Wipe off any excess lubricant.

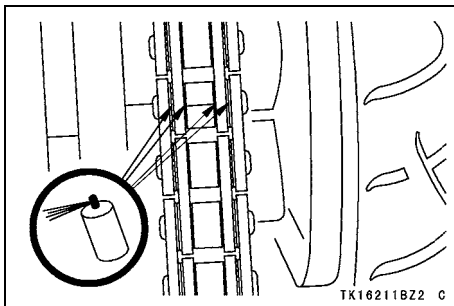

- Wipe off any lubricant that gets on the tire surface.

### ***Drive Chain Slack Inspection***

- Set the motorcycle up on its side stand.
- Clean the chain if it is dirty, and lubricate it if it appears dry.
- Rotate the rear wheel to find the position where the chain is tightest, and

measure the maximum chain slack by pulling up and pushing down the chain midway between the engine sprocket and rear wheel sprocket.

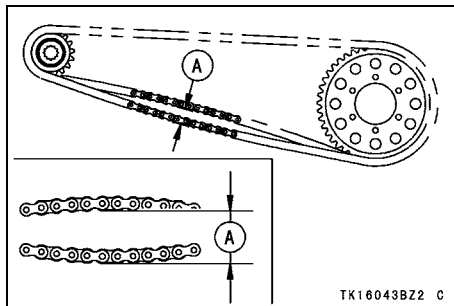

### **A. Chain Slack**

- If the drive chain is too tight or too loose, adjust it so that the chain slack is within the standard value.

### **Drive Chain Slack**

Standard: 20 ~ 30 mm (0.8 ~ 1.2 in.)

**Drive Chain Slack Adjustment**

- Remove the cap from the rear axle nut.
- Loosen the left and right chain adjuster locknuts.
- Remove the cotter pin, and loosen the axle nut.

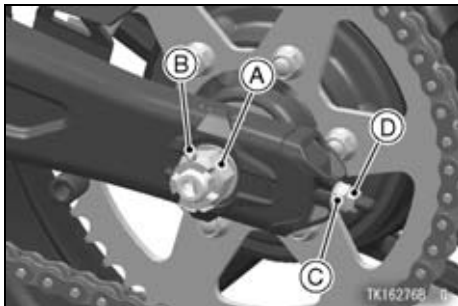

- A. Axle Nut
- B. Cotter Pin
- C. Adjuster
- D. Locknut

- If the chain is too loose, turn in the left and right chain adjusters evenly.
- If the chain is too tight, turn out the left and right chain adjusters evenly.
- Turn both chain adjusters evenly until the drive chain has the correct amount of slack. To keep the chain and wheel properly aligned, the left wheel alignment indicator should align with the same swingarm mark that the right wheel alignment indicator aligns with.

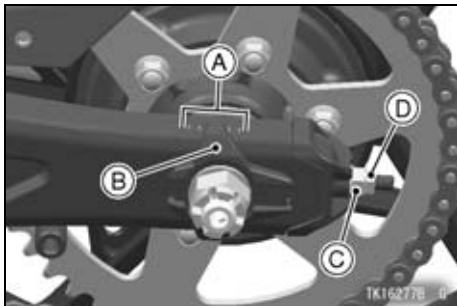

- A. Marks
- B. Wheel Alignment Indicator
- C. Adjuster
- D. Locknut

### NOTE

- *Wheel alignment can also be checked using the straightedge or string method.*

### **⚠ WARNING**

Misalignment of the wheel will result in abnormal wear, and may result in an unsafe riding condition. Align the rear wheel using the marks on the swingarm or measuring the distance between the center of the axle and swingarm pivot.

- Tighten both chain adjuster locknuts.
- Tighten the axle nut to the specified torque.

### Tightening Torque

Axle Nut:  
108 N·m (11.0 kgf·m, 79.7 ft·lb)

### NOTE

- *If a torque wrench is not available, this item should be serviced by an authorized Kawasaki dealer.*

- Rotate the wheel, measure the chain slack again at the tightest position, and readjust if necessary.
- Install a new cotter pin through the axle nut and axle, and spread its ends.

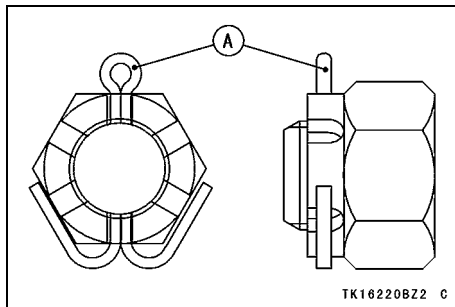

A. Cotter Pin

### NOTE

- When inserting the cotter pin, if the slots in the nut do not align with

*the cotter pin hole in the axle shaft, tighten the nut clockwise up to the next alignment.*

- *It should be within 30 degrees.*
- *Loosen once and tighten again when the slot goes past the nearest hole.*

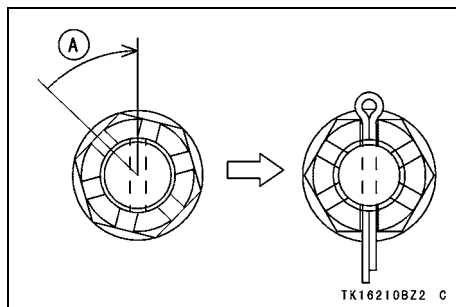

A. Turn Clockwise

 **WARNING**

A loose axle nut can lead to an accident resulting in serious injury or death. Tighten the axle nut to the proper torque and install a new cotter pin.

- Install the cap to the rear axle nut.
- Check the rear brake (see Brakes section).

## Brakes

If you feel there is something wrong when applying the brakes, have the brake system checked by an authorized Kawasaki dealer immediately.

 **WARNING**

Air in the brake lines diminish braking performance and can cause an accident resulting in injury or death. If the brake lever or pedal feels mushy when it is applied, there might be air in the brake lines or the brake may be defective. Have the brake checked immediately by an authorized Kawasaki dealer.

### *Brake Fluid Level Inspection*

- With the front brake fluid reservoir held horizontal, the brake fluid level must be above the lower level line.

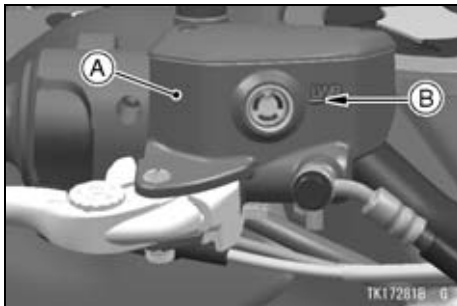

**A. Front Brake Fluid Reservoir**  
**B. Lower Level Line**

- With the rear brake fluid reservoir held horizontal, the brake fluid level must be kept between the upper and lower level lines.

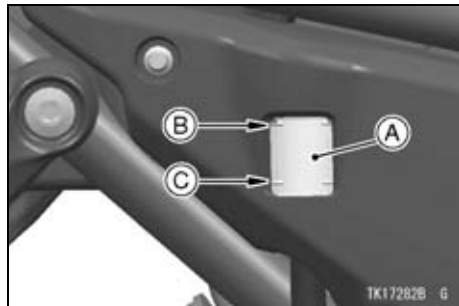

**A. Rear Brake Fluid Reservoir**  
**B. Upper Level Line**  
**C. Lower Level Line**

- If the fluid level is lower than the lower level line it may indicate that the fluid is leaking. In this case, have the brake system inspected by an authorized Kawasaki dealer.

### ***Brake Pad Wear Inspection***

Inspect the brakes for wear. For each front and rear disc brake caliper, if the

## 126 MAINTENANCE AND ADJUSTMENT

thickness of either pad lining is less than 1 mm (0.04 in.), replace both pads in the caliper as a set. Pad replacement should be done by an authorized Kawasaki dealer.

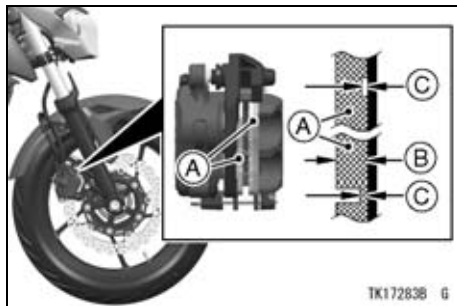

- A. Front Brake Pads
- B. Lining Thickness
- C. 1 mm (0.04 in.)

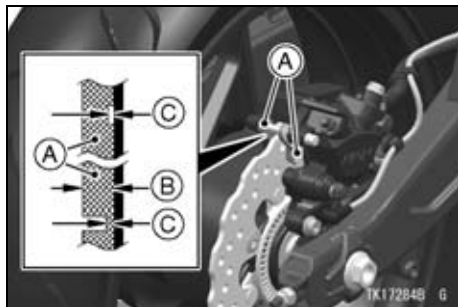

- A. Rear Brake Pads
- B. Lining Thickness
- C. 1 mm (0.04 in.)

## Brake Light Switches

### *Brake Light Switch Inspection*

- Turn the ignition switch on.
- The brake light should go on when the front brake is applied.

- If it does not, ask your authorized Kawasaki dealer to inspect the front brake light switch.
- Check the operation of the rear brake light switch by depressing the brake pedal. The brake light should go on after the proper pedal travel.

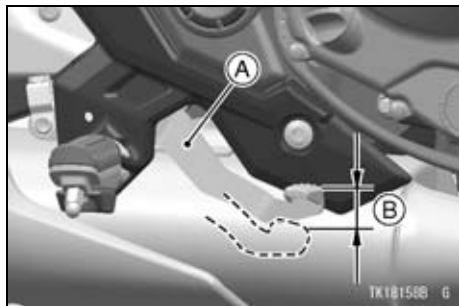

**A. Brake Pedal**  
**B. 10 mm (0.39 in.)**

- If the light does not come on, adjust the rear brake light switch.

### Brake Pedal Travel

10 mm (0.39 in.)
------------------

### Brake Light Switch Adjustment

- Remove the bolts and washers.
- Remove the right frame cover.

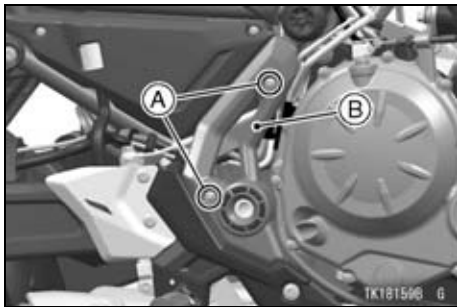

**A. Bolts and Washers**  
**B. Right Frame Cover**

- To adjust the rear brake light switch, move the switch up or down by turning the adjusting nut.

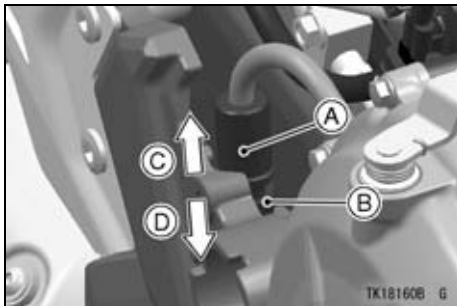

- A. Rear Brake Light Switch
- B. Adjusting Nut
- C. Lights sooner
- D. Lights later

### ***NOTICE***

To avoid damaging the electrical connections inside the switch, be sure that the switch body does not turn during adjustment.

- Install the right frame cover, and tighten its bolts together with the washers.

## **Suspension System**

### **Front Fork**

### ***NOTICE***

After riding on the normal road, the unpaved road and in the rainy weather, clean off any dirt (grit, mud or insect etc.) that stuck to inner tube before it hardens. If the motorcycle keeps running with the dirt stuck to the inner tube, the oil seal will be damaged and it causes the oil leak.

## Rear Shock Absorber

### *Spring Preload Adjustment*

The spring preload adjuster on the rear shock absorber has 7 positions.

#### Standard

3rd position

- Remove the bolts and washers.
- Remove the left frame cover.
- Remove the bolts.
- Remove the left side cover.

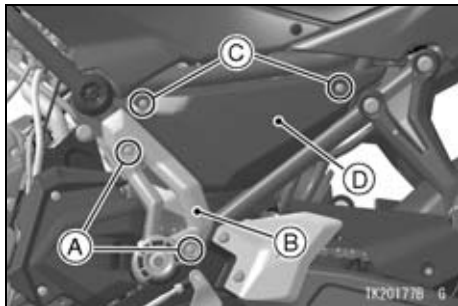

- A. Bolts and Washers
- B. Left Frame Cover
- C. Bolts
- D. Left Side Cover

- In accordance with the setting table, turn the preload adjuster with the wrench from the tool kit.

## 130 MAINTENANCE AND ADJUSTMENT

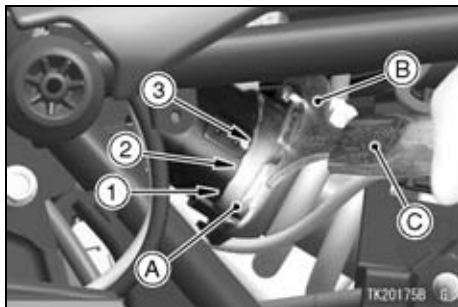

- A. Spring Preload Adjuster
- B. Wrench
- C. Handle

- Install the left frame cover, and tighten its bolts together with the washers.
- Install the left side cover, and tighten its bolts.

---

## Setting Table

---

### Rear Shock Absorber Spring Preload Setting

	Softest setting limit	<b>Standard</b>	Hardest setting limit
Adjuster Position	1st	<b>3rd</b>	7th
Spring Action	Weak	←→	Strong
Setting	Soft	←→	Hard
Load	Light	←→	Heavy
Road	Good	←→	Bad
Speed	Low	←→	High

## Wheels

### *Tire Pressure Inspection*

- Remove the air valve cap.
- Check the tire pressure often, using an accurate gauge.
- Make sure to install the air valve cap securely.

### NOTE

- *Measure the tire pressure when the tires are cold (that is, when the motorcycle has not been ridden more than 1.6 km (1 mile) during the past 3 hours).*
- *Tire pressure is affected by changes in ambient temperature and altitude, and so the tire pressure should be checked and adjusted when your riding involves wide variations in temperature or altitude.*



**A. Tire Pressure Gauge**

### Tire Air Pressure (when cold)

Front	225 kPa (2.25 kgf/cm <sup>2</sup> , 32 psi)
Rear	250 kPa (2.50 kgf/cm <sup>2</sup> , 36 psi)

### Tire Wear, Damage

As the tire tread wears down, the tire becomes more susceptible to puncture and failure. An accepted estimate is that 90% of all tire failures occur during the last 10% of tread life (90% worn).

So it is false economy and unsafe to use the tires until they are bald.

### ***Tire Wear Inspection***

- Measure the depth of the tread with a depth gauge, and replace any tire that has worn down to the minimum allowable tread depth.



**A. Tire Depth Gauge**

### **Minimum Tread Depth**

Front	—	1 mm (0.04 in.)
Rear	Under 130 km/h (80 mph)	2 mm (0.08 in.)
	Over 130 km/h (80 mph)	3 mm (0.12 in.)

- Visually inspect the tire for cracks and cuts, replacing the tire in case of bad damage. Swelling or high spots indicate internal damage, requiring tire replacement.

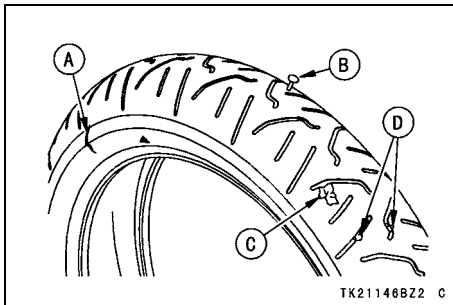

TK21146BZ2 C

- A. Crack or Cut
- B. Nail
- C. Swelling or High Spot
- D. Stone

- Remove any imbedded stones or other foreign particles from the tread.

### NOTE

- *Have the wheel balance inspected whenever a new tire is installed.*

### ⚠ WARNING

Tires that have been punctured and repaired do not have the same capabilities as undamaged tires and can suddenly fail, causing an accident resulting in serious injury or death. Replace damaged tires as soon as possible. To ensure safe handling and stability, use only the recommended standard tires for replacement, inflated to the standard pressure. If it is necessary to ride on a repaired tire, do not exceed 100 km/h (60 mph) until the tire is replaced.

### NOTE

- *When operating on public roadways, keep maximum speed under traffic law limits.*

**Standard Tire (Tubeless)**

Front	Make, Type: DUNLOP, SPORTMAX D214F W Size: 120/70ZR17 M/C (58W)
Rear	Make, Type: DUNLOP, SPORTMAX D214 W Size: 160/60ZR17 M/C (69W)

**WARNING**

**Mixing tire brands and types can adversely affect handling and cause an accident resulting in injury or death. Always use the same manufacturer's tires on both front and rear wheels.**

**WARNING**

**New tires are slippery and may cause loss of control and injury. A break-in period of 160 km (100 miles) is necessary to establish normal tire traction. During break-in, avoid sudden and maximum braking and acceleration, and hard cornering.**

**Battery**

The battery installed in this motorcycle is a sealed type, so it is not necessary to check the battery electrolyte level or add distilled water.

**NOTICE**

**Never remove the sealing strip, or the battery can be damaged. Do not install a conventional battery in this motorcycle, or the electrical system cannot work properly.**

Make	Yuasa Battery
Type	YTZ10S

**Battery Maintenance**

It is the owner's responsibility to keep the battery fully charged. Failure to do so can lead to battery failure and leave you stranded.

If you are riding your vehicle infrequently, inspect the battery voltage weekly using a voltmeter. If it drops below 12.8 volts, the battery should be charged using an appropriate charger (check with your Kawasaki dealer).

If you will not be using the motorcycle for longer than two weeks, the battery should be charged using an appropriate charger. Do not use an automotive-type quick charger that may overcharge the battery and damage it.

**NOTE**

- *Leaving the battery connected causes the electrical components (clock etc.) to make the battery discharged, resulting the over discharge of the battery. In this case, the repair or replacement of the battery is not included in the warranty. If you do not drive for four weeks or more, disconnect the battery from the vehicle.*

**Kawasaki-recommended chargers are:**

Battery Mate 150-9  
 OptiMate 4  
 Yuasa MB-2040/2060  
 Christie C10122S

If the above chargers are not available, use equivalent one.

For more details, ask your Kawasaki dealer.

### ***Battery Charging***

- Charge the battery following the instructions of your battery charger.
- The charger will keep the battery fully charged until you are ready to re-install the battery in the motorcycle (see Battery Installation).

## **DANGER**

- **Battery acid generates hydrogen gas which is flammable and explosive under certain conditions. It is present within a battery at all times, even in a discharged condition. Keep all flames and sparks (cigarettes) away from the battery.**
- **Wear eye protection when working with a battery. In the event of battery acid contact with skin, eyes, or clothing, wash the affected areas immediately with water for at least five minutes. Seek medical attention.**

## **⚠ WARNING**

**Battery posts, terminals and related accessories contain lead and lead compounds, chemicals known to the State of California to cause cancer and reproductive harm. Wash hands after handling.**

### ***Battery Removal***

- Make sure the ignition switch is turned off.
- Remove the rider's seat (see Seats section in the GENERAL INFORMATION chapter).
- Remove the bolts and clamps.

- Remove the bracket.

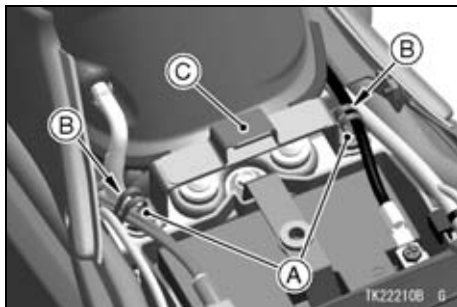

- A. Bolts**
- B. Clamps**
- C. Bracket**

- Remove the bolts.
- Remove the holder.

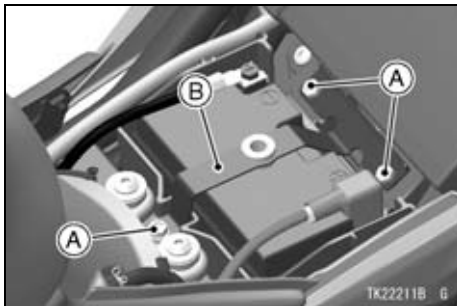

- A. Bolts**  
**B. Holder**

- Disconnect the negative (-) cable from the (-) terminal.
- Slide the red cap from the positive (+) terminal.
- Disconnect the positive (+) cable from the (+) terminal.

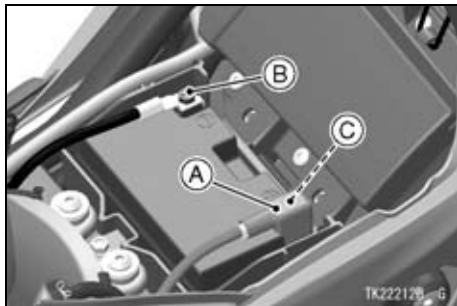

- A. Red Cap**  
**B. (-) Terminal**  
**C. (+) Terminal**

- Take the battery out of the battery case.
- Clean the battery using a solution of baking soda and water. Be sure that the cable connections are clean.

### ***Battery Installation***

- Place the battery on the battery case.

## 140 MAINTENANCE AND ADJUSTMENT

- Connect the positive (+) cable to the (+) terminal, and then connect the negative (-) cable to the (-) terminal.

### **NOTICE**

**Installing the negative (-) cable to the (+) terminal of the battery or the positive (+) cable to the (-) terminal of the battery can seriously damage the electrical system.**

- Put a light coat of grease on the terminals to prevent corrosion.
- Cover the (+) terminal with the red cap.
- Install the removed parts.

### **NOTE**

- *Install the clamps sideways so that the clamps are parallel to the bracket.*

- *Bend the clamps and hold the battery cables with them to prevent the cable from interfering with the edges of other parts.*

## **Headlight**









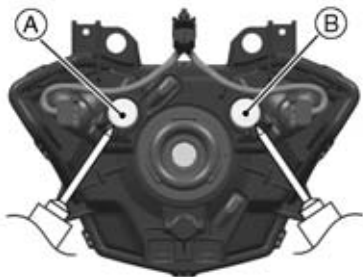







Headlight aiming should be done by an authorized Kawasaki dealer.

### **Headlight Aiming Adjustment**

### **NOTE**

- *The left and right adjusters on the headlight can move the direction of the headlight beam to up, down, left and right by turning each adjuster itself as the below table.*



A	B	C
 	 	D
 	 	E
 	 	F
 	 	G

TK23269B G

- A. Left Adjuster
- B. Right Adjuster
- C. Moving Direction of Headlight Beam
- D. Up
- E. Down
- F. Left
- G. Right

## 142 MAINTENANCE AND ADJUSTMENT

- To move the headlight beam leftward, turn the left adjuster clockwise and turn the right adjuster counterclockwise same number until the beam points straight ahead.
- To move the headlight beam rightward, turn the left adjuster counterclockwise and turn the right adjuster clockwise same number until the beam points straight ahead.
- If not properly adjusted horizontally, the beam will point to one side rather than straight ahead.
- To move the headlight beam upward, turn the both adjusters clockwise same number.
- To move the headlight beam downward, turn the both adjusters counterclockwise same number.

- If adjusted too low, neither low nor high beam will illuminate the road far enough ahead. If adjusted too high, the high beam will fail to illuminate the road close ahead, and the low beam will blind oncoming drivers.

### NOTE

- *On high beam, the brightest points should be slightly below horizontal. The proper angle is 0.4 degrees below horizontal. This is a 50 mm (2.0 in.) drop at 7.6 m (25 ft) measured from the center of the headlight, with the motorcycle on its wheels and the rider seated.*

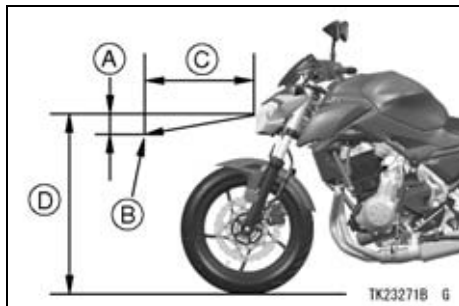

- A. 50 mm (2.0 in.)**
- B. Center of Brightest Spot**
- C. 7.6 m (25 ft)**
- D. Height of Headlight Center**

## Fuses

Fuses are arranged in the fuse boxes located behind the left middle fairing. The main fuse is located behind the left side cover. If a fuse fails during operation, inspect the electrical system to determine the cause, and then replace it with a new fuse of proper amperage.

If the fuse fails repeatedly, there is something wrong with the electrical system. Have the motorcycle checked by an authorized Kawasaki dealer.

The main fuse removal should be done by an authorized Kawasaki dealer.

## 144 MAINTENANCE AND ADJUSTMENT

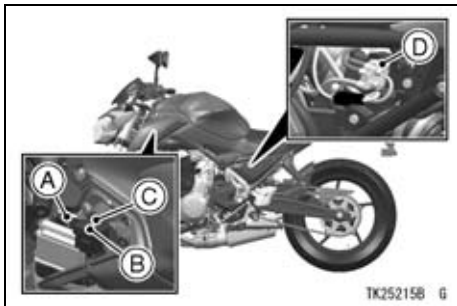

- A. Turn Signal Light Fuse
- B. Fuse Box
- C. Fuse Box (only on ABS model)
- D. Main Fuse

To access the main fuse:

- Remove the bolts and washer.

- Remove the left side cover.

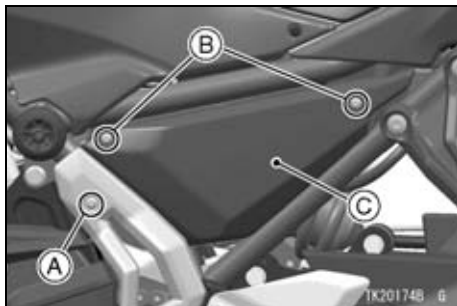

- A. Bolt and Washer
- B. Bolts
- C. Left Side Cover

- Check the fuse.

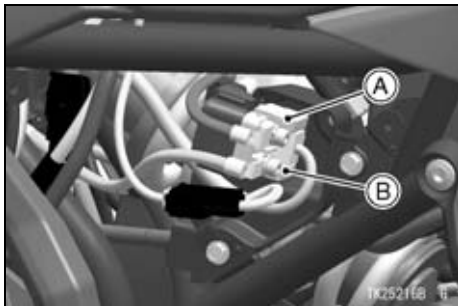

- A. Main Fuse 30 A
- B. Spare Fuse 30 A

- Install the left side cover, and tighten the bolts together with the washer.

To access the fuse boxes:

- Remove the quick rivets and bolts.

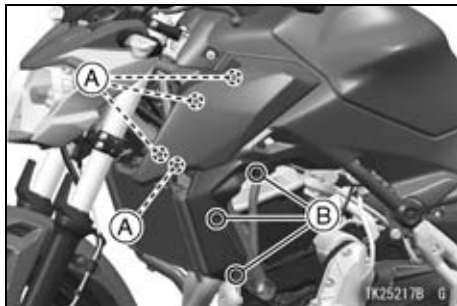

- A. Quick Rivets
- B. Bolts

- Pull the left middle fairing outward to clear the projections, and remove the left middle fairing.



- A. Projections
- B. Left Middle Fairing

● Check the fuses.

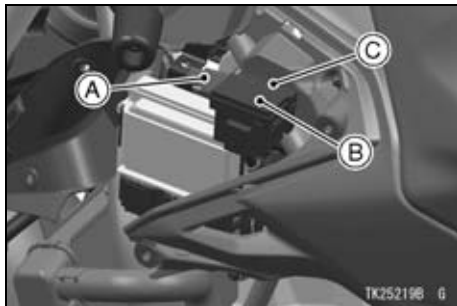

- A. Turn Signal Light Fuse
- B. Fuse Box
- C. Fuse Box (only on ABS model)

● Insert the projections of the left middle fairing into the grommets of the left fuel tank cover.

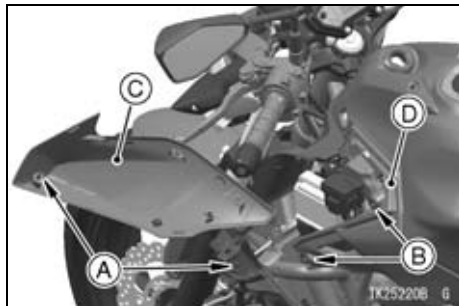

- A. Projections
- B. Grommets
- C. Left Middle Fairing
- D. Left Fuel Tank Cover

- Install the quick rivets and tighten the bolts.

## **⚠ WARNING**

Substituting fuses can cause wiring to overheat, catch fire and/or fail. Do not use any substitute for the standard fuse. Replace the blown fuse with a new one of the correct capacity, as specified on the fuse boxes and main fuse.

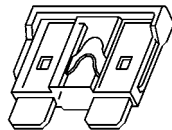

A

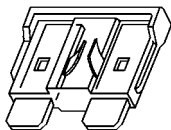

B

TK25007BZ2 C

- A. Normal
- B. Failed

## General Lubrication

Lubricate the points shown below, with either engine oil or regular grease, in accordance with the Periodic Maintenance Chart or whenever the vehicle has been operated under wet or rainy conditions.

Before lubricating each part, clean off any rusty spots with rust remover and wipe off any grease, oil, dirt, or grime.

### *Apply motor oil to the following pivots*

- Side Stand
- Clutch Lever
- Front Brake Lever
- Rear Brake Pedal

### *Lubricate the following cables with a pressure cable luber*

- (K) Clutch Inner Cable
- (K) Throttle Inner Cables

### *Apply grease to the following points*

- (K) Clutch Inner Cable Upper End
- (K) Throttle Inner Cable Upper Ends

(K): Should be serviced by an authorized Kawasaki dealer.

### NOTE

○ *After connecting the cables, adjust them.*

## Cleaning

---

### General Precautions

---

Frequent and proper care of your vehicle will enhance its appearance, optimize overall performance, and extend its useful life. Covering your vehicle with a high quality, breathable vehicle

cover will help protect its finish from harmful UV rays, pollutants, and reduce the amount of dust reaching its surfaces.

 **WARNING**

**Build-up of debris or flammable material in and around the vehicle chassis, engine, and exhaust can cause mechanical problems and increase the risk of fire. When operating the vehicle in conditions that allow debris or flammable material to collect in and around the vehicle, inspect the engine, electrical component and exhaust areas frequently. If debris or flammable materials have collected, park the vehicle outside and stop the engine. Allow the engine to cool, then remove any collected debris. Do not park or store the vehicle in an enclosed space prior to inspecting for build-up of debris or flammable materials.**

## 150 MAINTENANCE AND ADJUSTMENT

- Be sure the engine and exhaust are cool before washing.
- When washing the vehicle, always use a mild neutral detergent and water.
- Avoid applying all harsh chemicals, solvents, degreaser, oil remover, electrical contact cleaner, and household cleaning products such as ammonia-based window cleaners. They will damage or deteriorate painted parts, plastic parts, rubber parts and other synthetic parts including covers and headlight lens.
- Avoid applying degreaser to seals, brake pads, and tires.
- Gasoline, brake fluid, and coolant will damage the finish of painted and plastic surfaces: wash them off immediately.
- Avoid wire brushes, steel wool, and all other abrasive pads or brushes.

- Take care when washing the headlight lens and other plastic parts as they can easily be scratched.

### NOTE

- *After riding in an area where the roads are salted or near the ocean, immediately wash your vehicle with cold water. Do not use warm water as it accelerates the chemical reaction of the salt. After drying, apply a corrosion protection spray on all metal and chrome surfaces to prevent corrosion.*
- *Condensation may form on the inside of the headlight lens after riding in the rain, washing the vehicle or humid weather. To remove the moisture, start the engine and turn on the headlight. Gradually the condensation on the inside of the lens will clear off.*

## ***Radiator***

Clean off any obstructions with a stream of low-pressure water.

### ***NOTICE***

**Using high-pressure water, as from a car wash facility, could damage the radiator fins and impair the radiator's effectiveness. Do not obstruct or deflect airflow through the radiator by installing unauthorized accessories in front of the radiator or behind the cooling fan. Interference with the radiator airflow can lead to overheating and consequent engine damage.**

## ***Matte Paint Parts***

- When washing the vehicle, always use a mild neutral detergent and water, or cleaners for matte paint.
- The matte paint effect may be lost when the paint is excessively rubbed.
- If any doubt, consult an authorized Kawasaki dealer.

## ***Plastic Parts***

After washing, use a soft cloth to gently dry plastic parts. When dry, treat the headlight lens and other non-painted plastic parts with an approved plastic cleaner/polisher product.

**NOTICE**

**Plastic parts may deteriorate and break if they come in contact with chemical substances or household cleaning products such as gasoline, brake fluid, window cleaners, thread-locking agents, or other harsh chemicals. If a plastic part comes in contact with any harsh chemical substance, wash it off immediately with water and a mild neutral detergent, and then inspect for damage. Avoid using abrasive pads or brushes to clean plastic parts, as they will damage the part's finish.**

**Chrome and Aluminum**

Chrome and uncoated aluminum parts can be treated with a chrome/aluminum polish. Coated aluminum

should be washed with a mild neutral detergent and finished with a spray polish. Aluminum wheels, both painted and unpainted can be cleaned with special non-acid based wheel spray cleaners.

**Leather, Vinyl, and Rubber**

If your vehicle has leather accessories, special care must be taken. Use a leather cleaner/treatment to clean and care for leather accessories. Washing leather parts with detergent and water will damage them, shortening their life.

Vinyl parts should be washed with the rest of the vehicle, then treated with a vinyl treatment.

The sidewalls of tires and other rubber components should be treated with a rubber protectant to help prolong their useful life.

---

## Where to be Careful

---

Avoid spraying water with any great force near the following places.

- Disc brake master cylinder and caliper.
- Under the seat and fuel tank - if water gets into the fuse box or battery, it can ground out the spark. When this happens the vehicle will not operate properly and the affected parts must be wiped dry.

## **NOTICE**

**Coin operated, high pressure spray washers are not recommended. Water may be forced into bearings and other components causing eventual failure from rust and corrosion. Some soaps are highly alkaline and may leave a residue or cause spotting.**

## **NOTE**

- *Abrasive cleanser or high pressure washer will damage the surface finish on the bodywork.*

---

## Washing Your Vehicle

---

- Before washing, precautions must be taken to keep water off the following parts.

## 154 MAINTENANCE AND ADJUSTMENT

Muffler rear opening - cover with a plastic bag.

Ignition switch - cover the keyhole with tape.

- Rinse your vehicle with cold water from a garden hose to remove any loose dirt.
- Mix a mild neutral detergent (designed for motorcycles or automobiles) and water in a bucket. Use a soft cloth or sponge to wash your vehicle.
- After washing, rinse your vehicle thoroughly with clean water to remove any residue (residue from the

detergent can damage parts of your vehicle).

- Remove the plastic bag and tape.
- Use a soft cloth to dry your vehicle. As you dry, inspect your vehicle for chips and scratches. Do not let the water air dry as this can damage the painted surfaces.
- Carefully ride your vehicle at a slow speed and apply the brakes several times. This helps dry the brakes and restores them to normal operating performance.

---

## APPENDIX

---

### Storage

Whenever your motorcycle will not be in use for a long period, proper storage is essential.

It consists of checking and replacing missing or worn parts; lubricating parts to ensure that they do not corrode and, in general, preparing the motorcycle so that when the time comes to use it again, it will be in top condition.

See your authorized Kawasaki dealer for this service or do the following.

#### ***Preparation for Storage***

Make sure the area is well ventilated and free from any source of flame.

### **DANGER**

**Exhaust gas contains carbon monoxide, a colorless, odorless poisonous gas. Inhaling carbon monoxide can cause serious brain injury or death. DO NOT run the engine in enclosed areas. Operate only in a well-ventilated area.**

 **WARNING**

**Gasoline is extremely flammable and can be explosive under certain conditions, creating the potential for serious burns.**

- Turn the ignition key off.
- Do not smoke.
- Make sure the area is well ventilated and free from any source of flame or sparks; this includes any appliance with a pilot light.

 **WARNING**

**Gasoline is a toxic substance. Dispose of gasoline properly. Contact your local authorities for approved disposal methods.**

- Clean the entire vehicle thoroughly.
- Run the engine for about five minutes to warm the oil, shut it off, and drain the engine oil. (see Engine Oil section in the MAINTENANCE AND ADJUSTMENT chapter)

 **WARNING**

**Engine oil is a toxic substance. Dispose of used oil properly. Contact your local authorities for approved disposal methods or possible recycling.**

- Put in fresh engine oil.
- Empty the fuel from the fuel tank using a pump or syphon.
- Remove the spark plugs and add fogging oil into the combustion chambers. If the spark plugs cannot be removed, take the motorcycle to an authorized Kawasaki dealer.
- Set the motorcycle on a stand so that both wheels are raised off the ground. (If this cannot be done, put boards under the front and rear wheels to keep dampness away from the tire rubber.)
- Spray oil on all unpainted metal surfaces to prevent rusting. Avoid getting oil on rubber parts or in the brakes.
- Lubricate the drive chain and all the cables.
- Remove the battery, and store it where it will not be exposed to direct sunlight, moisture, or freezing temperatures. During storage it should be given a slow charge (one ampere or less) about once a month. Keep the battery well charged especially during cold weather.
- Tie plastic bag over the muffler to prevent moisture from entering.
- Put a cover over the motorcycle to keep dust and dirt from collecting on it.

### ***Preparation after Storage***

- Remove the plastic bag from the muffler.
- Charge the battery if necessary and install the battery in the motorcycle.
- Fill the fuel tank with fresh fuel.
- Check all the points listed in the Daily Checks section.
- Lubricate the pivots, bolts, and nuts.

## **Troubleshooting Guide**

### ***If a Problem Occurs***

Performing daily checks and periodic maintenance prevents unexpected troubles from occurring. In case of a breakdown, take emergency measures and contact your Kawasaki dealer to request repair. For safety, inspection and maintenance should be done within your knowledge and ability. If you are not confident in completing an inspection or maintenance, ask an authorized Kawasaki dealer to do the work.

 **WARNING**

- When carrying out an inspection, follow the precautions below.
- Secure a place where you can work in safety without obstructing traffic around you. Do not carry out any inspection unless it is safe.
- Support the motorcycle on a firm, level surface with the stand.
- The engine and muffler will become hot during operation. To avoid burns etc., do not touch the hot engine or muffler just after the engine has stopped.
- Exhaust gas contains harmful substances such as carbon monoxide. Do not run the engine in an enclosed garage or poorly ventilated area.
- Wait until the engine cools down before carrying out inspection and maintenance or replenishing fuel. Make sure the area is well ventilated and free from any source of flame or sparks. Do not place any appliance with a pilot light nearby.
- If a test ride is needed, ride in a safe area and pay close attention to traffic around you.

When any warning indicators go on or blink, have the motorcycle inspected by an authorized Kawasaki dealer immediately.



***If the Engine Does Not Start***

When the engine turns over but the engine does not start, inspect as follows.

- Check the fuel level in the fuel tank. If only a small quantity of fuel remains in the bottom, replenish the fuel tank. (Fuel in the tank cannot be completely consumed.)
- Leaving the motorcycle unused for a long time may cause fuel in the tank to deteriorate. In that case, ask an authorized Kawasaki dealer for inspection.
- When the engine warning indicator on the meter goes on and stays on, there may be a problem with the fuel injection system. Ask an authorized Kawasaki dealer for inspection and maintenance.
- The motorcycle is equipped with a vehicle-down sensor which stops the engine automatically when the motorcycle falls down. When the starter button is pressed after the motorcycle has fallen down, the engine does not start. To start the engine, switch the ignition key to the “OFF” position and then back to the “ON” position.

If the engine will not start after completing the above inspection and maintenance, there may be something wrong with another system such as the ignition system. Ask an authorized Kawasaki dealer for inspection and maintenance.

When the starter motor does not rotate, inspect as follows.

- Check the position of the engine stop switch. Push the engine stop switch in the  position if it is in the  position.
- Make sure that the gear position is in the neutral position. If not, shift the transmission into neutral.

- Inspect the fuse condition. If any fuse has blown, replace it with a new one of the same amperage.

 **WARNING**

**Substituting fuses can cause wiring to overheat, catch fire and/or fail. Use only standard fuses of the correct capacity and specifications.**

- Check the battery cable connections etc. (see page 139). If necessary, tighten the connecting bolts to securely connect them.
- In case of slow blinking of the turn signal lights, low volume of the horn sound, or when you press the starter button and hear a click but the starter motor does not rotate, battery charging status is not good. Refresh the battery's charge (see page 137) and check if the starter motor rotates.
- Even after a refresh charge, if the starter motor stops rotating the engine properly, the battery may have deteriorated. Have the battery inspected by an authorized Kawasaki dealer.

If the starter motor will not start after completing the above inspection and maintenance, there may be something wrong with another part such as the starter motor. Ask an authorized Kawasaki dealer for inspection and maintenance.

***If the Engine Stalls or Runs Poorly***

- Check the fuel level in the fuel tank. If only a small quantity of fuel remains, replenish the fuel tank. (Fuel in the tank cannot be completely consumed.)
- Raise the side stand fully up before starting the engine. (If you try to move off with the side stand is still down, the engine will stop.)
- Make sure that correct fuel is used. If not, replace the fuel the correct type (see page 73).
- Due to too much play in the clutch lever, the clutch may not disengage. If there is any problem, adjust the clutch lever free play correctly.
- In case of slow blinking of the turn signal lights, low volume of the horn sound, or when you press the starter button and hear a click but the starter motor does not rotate, the battery is discharged. Check the connections of the battery terminals for looseness (see page 139). If necessary, tighten the bolts to remove the looseness. If the above methods cannot solve the problems, ask an authorized Kawasaki dealer for inspection and maintenance.
- If the warning indicator goes on and coolant temperature warning indicator is displayed, the engine may have overheated. Check the coolant level in the reserve tank after the engine cools down. If the coolant quantity is less than the lower level, replenish the coolant or soft water up to the upper level (see page 110). Ask an authorized Kawasaki dealer to identify the cause of the overheat immediately.
- When the engine warning indicator on the meter goes on and stays on, there is something wrong with the fuel injection system. Ask an authorized Kawasaki dealer for inspection and maintenance.

If the engine stalls after completing the above inspection and maintenance, there may be something wrong with other system. Ask an authorized Kawasaki dealer for inspection and maintenance.

## **Your Warranty/Owner Satisfaction**

Welcome to the Kawasaki family!

Congratulations on buying your Kawasaki vehicle. You've chosen a great, high-quality product with state-of-the-art features and built to Kawasaki's high standards. Your satisfaction is important to your authorized Kawasaki dealer and to Kawasaki Motors Corp., U.S.A. Here is some important information regarding your vehicle's limited warranty.

### ***Frequently Asked Questions***

#### **What is a Limited Warranty?**

The most important thing to know about your warranty is that it protects you from manufacturing defects in material or workmanship during the warranty period. You can find the warranty period in the Kawasaki Limited Warranty Certificate your Kawasaki dealer provided to you at the time of sale. The warranty does not cover the cost of regularly-scheduled maintenance. The warranty also does not apply to the normal wear of items such as tires, brake pads, transmission drive belts, chains, sprockets, etc.

### **What is the Kawasaki Protection Plus?**

Much of the warranty coverage offered by the limited warranty can be extended by purchasing the Kawasaki Protection Plus (KPP). See your Kawasaki dealer or go to [Kawasaki.com](http://Kawasaki.com) for more information if you don't already have the KPP.

### **What Am I Responsible For?**

You are responsible for maintaining your vehicle according to the maintenance schedule shown in this owner's manual.

You are responsible for notifying your dealer immediately if there is a problem, and you, as the owner, will need to authorize the dealer to inspect the unit.

You will be responsible for paying for routine maintenance, including the first scheduled service. You can have the required servicing done by your Kawasaki dealer (recommended) or an equally-qualified service facility. You can also do your own maintenance work if you have the proper tools, service references, and mechanical skills. However, if a failure is found to be caused by improper servicing, it would not be covered by the limited warranty.

You may purchase a Kawasaki Service Manual and any necessary special tools directly from your Kawasaki dealer.

You will be responsible for paying for repairs needed because of an accident, to replace worn parts such as tires, chains, brakes, and for repairs needed because of a lack of maintenance, misuse or racing.

Whether you do it yourself or take your vehicle to a Kawasaki dealer, be sure to record your service in the Maintenance Record section of this Owner's Manual. Keep all receipts for the service and/or items necessary to perform the maintenance so that in the event of a failure you can document the service history.

### **What Are The Dealership's Responsibilities?**

Your Kawasaki dealer offers a wide range of services, parts, accessories, and information on your product and on Kawasaki.

Each dealer is independently owned and operated and is responsible for the dealership's operations, its repair, warranty, and service work, and its personnel.

Your dealer is responsible for completing the set up and pre-delivery service of your new Kawasaki vehicle. The dealership should also explain its operation, maintenance, and warranty provisions so you understand them at the time of purchase or at any other time you have questions.

The dealership is responsible for inspecting your Kawasaki vehicle if there is a failure, investigating the cause of the problem, and getting any needed authorization from Kawasaki if the repair is one that will be covered by the limited warranty. The dealership will also file all necessary paperwork. The dealership is responsible for correctly completing any necessary repairs, whether they are covered by the limited warranty or not.

### **How Do I Get Warranty Service?**

If there is a problem with your vehicle within the limited warranty period, you will need to schedule a service appointment and provide any maintenance records to an authorized Kawasaki dealer for inspection and diagnosis. You can go to any Kawasaki dealer for warranty repairs. Your Kawasaki dealer will inspect your vehicle and give you the results of the inspection. The dealer will perform the repairs at no cost to you if it is determined that the problem is covered by the warranty.

Kawasaki will work with your dealer to resolve any warranty issues. No authorization for warranty work can be given until your vehicle has been inspected by a Kawasaki dealer.

### **What if I am not Satisfied With My Warranty Service?**

If you aren't satisfied with your dealership's repair work or operations, it is best to discuss the situation with the appropriate dealership manager. If you have already done this, then contact the dealership's owner or general manager to request a review of the issue.

If you are unable to resolve a problem after consulting with the dealership management and need further assistance, contact Kawasaki Motors Corp., U.S.A. at the address below. Please be certain to provide the model, vehicle identification number (VIN), mileage or hours of use, accessories, dates that events occurred and what action has been taken by both you and your dealer. Include the name and address of the dealership. To assist us in resolving your inquiry, please include copies of related receipts and any other pertinent information including the name of the dealership personnel with whom you have been working. Upon receipt of your correspondence, Kawasaki Motors Corp., U.S.A. will contact the dealership and work with it in resolving your problem.

### **Want to Contact Kawasaki?**

This owner's manual should answer most of your questions about your Kawasaki. Your Kawasaki dealer should either be able to answer any other questions you might have immediately or be able to find the answer for you.

Please send your correspondence to:

Consumer Services  
Kawasaki Motors Corp., U.S.A.  
P.O. Box 25252  
Santa Ana, CA 92799-5252  
(949) 460-5688

## Reporting Safety Defects

**(For Products Sold in the United States of America, District of Columbia, and U.S. Territories Only)**

If you believe that your vehicle has a defect which could cause a crash or could cause injury or death, you should immediately inform the National Highway Traffic Safety Administration (NHTSA) in addition to notifying Kawasaki Motors Corporation, U.S.A.

If NHTSA receives similar complaints, it may open an investigation, and if it finds that a safety defect exists in a group of vehicles, it may order a recall and remedy campaign. However, NHTSA cannot become involved in individual problems between you, your dealer, or Kawasaki Motors Corporation, U.S.A.

To contact NHTSA, you may either call the Auto Safety Hotline toll-free at 1-800-424-9393 (or 366-0123 in Washington, D.C. area) or write to: NHTSA, U.S. Department of Transportation, Washington, D.C. 20590. You can also obtain other information about motor vehicle safety from the Hotline.

## **Environmental Protection**

To help preserve the environment, properly discard used batteries, tires, oils and fluids, or other vehicle components that you might dispose of in the future. Consult your authorized Kawasaki dealer or local environmental waste agency for their proper disposal procedure. This also applies to disposal of the entire vehicle at the end of its life.

**MAINTENANCE RECORD**

Owner Name.....

Address .....

Phone Number .....

Engine Number .....

Vehicle Number.....

Key Code .....

Selling Dealer Name .....

Phone Number .....

Warranty Start Date .....

**Note:** Keep this information and a spare key in a secure location.

Date	Odometer Reading	Maintenance Performed	Dealer Name	Dealer Address











# ER650GJ/HJ



**Kawasaki Heavy Industries, Ltd.** Motorcycle & Engine Company

Printed in Thailand

GB